



**Trademarks..... 3**  
**How to Read This Manual..... 4**

## 1. Originals

---

**Sizes and Weights of Recommended Originals..... 6**  
    Non-recommended originals for the document feeder.....7  
**Sizes Detectable by the Auto Paper Select..... 8**  
    Sizes difficult to detect.....9  
**Missing Image Area..... 10**

## 2. Paper and Other Media

---

**Paper and Other Media Supported by This Machine..... 12**  
    Paper Sizes .....12  
    Paper Recommendations .....23  
**Printable Area..... 29**  
**Loading Paper..... 30**  
    Loading Paper in Tray 1 .....30  
    Loading Paper in Tray 2 and the Optional Paper Feed Unit .....31  
    Loading paper in Paper Bank PS470 (2000-sheet Large Capacity Tray) .....34  
    If you load a paper size that is not selected automatically .....35  
    Changing the paper type.....37  
    Loading Paper in the Bypass Tray .....38





### 3. Troubleshooting

---

<b>Error &amp; Status Messages on the Control Panel.....</b>	<b>45</b>
<b>Printer Does Not Print .....</b>	<b>59</b>
<b>Other Printing Problems .....</b>	<b>62</b>
<b>Removing Misfed Paper.....</b>	<b>68</b>
Detaching the 2 Tray Finisher .....	69
Detaching the PT460 (Multi-bin) .....	70
Opening and Closing the Duplex Reversal Unit .....	71
When "Paper Misfeed: A" Appears.....	73
When "Paper Misfeed: B" Appears.....	74
When "Paper Misfeed: R" Appears.....	76
When "Paper Misfeed:Y" Appears.....	80
When "Paper Misfeed: Z1" Appears .....	81
When "Original Misfeed: P" Appears .....	83
<b>Removing Jammed Staples.....</b>	<b>87</b>
<b>Adding Staples .....</b>	<b>89</b>
<b>Removing Punch-hole Chips .....</b>	<b>92</b>
When the message appears even after removing the Punch-hole chips .....	93
<b>INDEX .....</b>	<b>94</b>





## Trademarks

Microsoft, Windows and Windows NT are registered trademarks of Microsoft Corporation in the United States and/or other countries.

PostScript is a registered trademark of Adobe Systems Incorporated.

PCL is a registered trademark of Hewlett-Packard Company.

IPS-PRINT©1999-2000 Oak Technology, Inc., All rights reserved.

Ethernet is a registered trademark of Xerox Corporation.

Other product names used herein are for identification purposes only and might be trademarks of their respective companies. We disclaim any and all rights in those marks.

---

### Notes:

---

Some illustrations in this manual might be slightly different from the machine.

Certain options might not be available in some countries. For details, please contact your local dealer.

Fax options are not sold in some areas.

---

### Note

---

- The product name of Windows® 95 is Microsoft® Windows® 95.
- The product name of Windows® 98 is Microsoft® Windows® 98.
- The product name of Windows® Me is Microsoft® Windows® Millennium Edition (Windows Me).
- The product name of Windows® 2000 are as follows:
  - Microsoft® Windows® 2000 Server
  - Microsoft® Windows® 2000 Professional
- The product name of Windows NT® 4.0 are as follows:
  - Microsoft® Windows NT® Server 4.0
  - Microsoft® Windows NT® Workstation 4.0



# How to Read This Manual

---

## Symbols

---

In this manual, the following symbols are used:

 **WARNING:**

This symbol indicates a potentially hazardous situation which, if instructions are not followed, could result in death or serious injury.

 **CAUTION:**

This symbol indicates a potentially hazardous situation which, if instructions are not followed, may result in minor or moderate injury or damage to property.

\* The statements above are notes for your safety.

 **Important**

If this instruction is not followed, paper might be misfed, originals might be damaged, or data might be lost. Be sure to read this.

 **Preparation**

This symbol indicates the prior knowledge or preparations required before operating.

 **Note**

This symbol indicates precautions for operation, or actions to take after misoperation.

 **Limitation**

This symbol indicates numerical limits, functions that cannot be used together, or conditions in which a particular function cannot be used.





 **Reference**

This symbol indicates a reference.

[    ]

Keys that appear on the machine's panel display.

Keys and buttons that appear on the computer's display.

【    】

Keys built into the machine's control panel.

Keys on the computer's keyboard.

















# 1. Originals

## Sizes and Weights of Recommended Originals

### ❖ Metric version

Where Original Is Placed	Original Size	Original Weight
Exposure glass	Up to A3	--
Document feeder	1-sided originals: A3  – B6  	40 – 128g/m <sup>2</sup>
	2-sided originals: A3  – A5  	52 – 105g/m <sup>2</sup>

### ❖ Inch version

Where Original Is Placed	Original Size	Original Weight
Exposure glass	Up to 11" × 17"	--
Document feeder	1-sided originals: 11" × 17"  – 5½" × 8½"  	11 – 34 lb.
	2-sided originals: 11" × 17"  – 5½" × 8½"  	14 – 28 lb.

### Note

- The number of originals that can be placed in the document feeder is about 80.
- The weight range for originals in the Mixed Size mode is 52-81g/m<sup>2</sup>, 13.8-21.5 lb.



---

## Non-recommended originals for the document feeder

---

Placing the following types of originals in the document feeder can cause paper misfeeds or result in damage to the originals. Place these originals on the exposure glass instead.

- Originals other than those specified in ⇒ p.6 “[Sizes and Weights of Recommended Originals](#)”
- Stapled or clipped originals
- Perforated or torn originals
- Curled, folded, or creased originals
- Pasted originals
- Originals with any kind of coating, such as thermal fax paper, art paper, aluminum foil, carbon paper, or conductive paper
- Originals with perforated lines
- Originals with indexes, tags, or other projecting parts
- Sticky originals such as translucent paper
- Thin originals that have low stiffness
- Thick originals such as postcards
- Originals of inappropriate weight
- Bound originals such as books
- Transparent originals such as OHP transparencies or translucent paper
- Originals that have correction fluid or ink on them that has not completely dried



## Sizes Detectable by the Auto Paper Select

### ❖ Metric version

Size	A3	B4	A4	B5	A5	11" × 17"	8½" × 14"	8½" × 11"	5½" × 8½"	8½" × 13"
Location of the original										<sup>*1</sup>
Exposure glass	○	○	○	○	×	×	○	×	×	○
Document feeder	○	○	○	○	○	×	×	×	×	○

<sup>\*1</sup> You can select from 8½" × 13", 8¼" × 13" or 8" × 13" with the User Tools (System Settings). See Copy Reference <Advanced Features>.

### ❖ Inch version

Size	A3	B4	A4	A4	B5	A5	11" × 17"	8½" × 14"	8½" × 11"	5½" × 8½"	8½" × 13"	8" × 10"	10" × 14"
Location of the original													
Exposure glass	×	×	×	×	×	×	○	○	○	×	×	○	○
Document feeder	○	×	○	×	×	×	○	○	○	○	×	×	○





---

## Sizes difficult to detect

---

It is difficult for the machine to detect the sizes of the following originals, so select the paper size manually.

- Originals with indexes, tags, or other projecting parts
- Transparent originals such as OHP transparencies or translucent paper
- Dark originals with a lot of text and drawings
- Originals which partially contain a solid image
- Originals which have solid images at their edges





## Missing Image Area

### ❖ Exposure glass

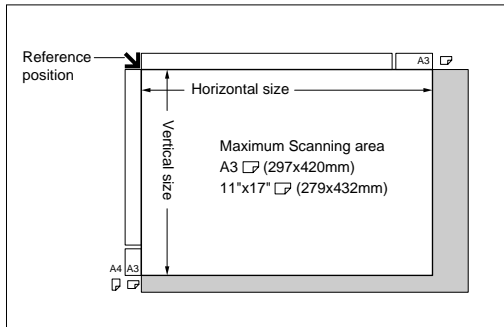

CP01AEE

### ❖ Document feeder

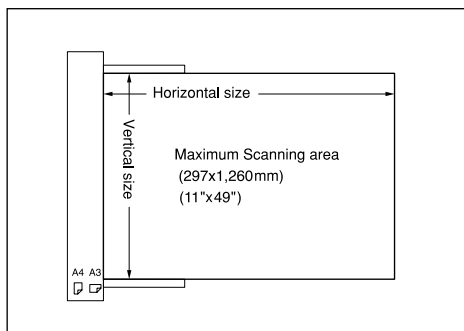

CP02AEE



 **Limitation**

- Even if you correctly place originals in the document feeder or on the exposure glass, 3mm (0.1") margins on all four sides of the original might not be copied.
- Make sure the original is placed correctly so that it is fed straight.
- When placing paper 433mm or larger in the document feeder (ADF), there are cases when the paper will be jammed, creased, or not fed.
- The maximum value for the system length setting is 1260mm (49").





## 2. Paper and Other Media



### Paper and Other Media Supported by This Machine

#### Paper Sizes

This section describes the type, size, feed direction, and maximum amount of paper that can be loaded into each paper tray in this printer.

 **Note**

- The following symbols and terminology are used to represent the feed direction.













In this manual	On the panel display	Paper feed direction
 ← (Feed direction)	A4 (210 × 297) 8 1/2 × 11	Short-edge feed direction
 ← (Feed direction)	A4 (297 × 210) 11 × 8 1/2	Long-edge feed direction

- Be careful of the paper feed direction. The direction is determined for each paper size.



## ❖ Input Paper Sizes (Metric version)

	Feed direction	Size (mm)	Bypass Tray	Paper Tray (Tray 1)	Paper Feed Unit (Tray 2/3/4)	2000-sheet Large Capacity Tray
A3		297 × 420	☆	×	⊙	×
B4 JIS		257 × 364	☆	×	☆	×
A4		210 × 297	☆	×	☆	×
		297 × 210	☆	●	⊙	●
B5 JIS		182 × 257	☆	×	☆	×
		257 × 182	☆	×	⊙	×
A5		148 × 210	☆	×	×	×
		210 × 148	☆	×	⊙	×
B6 JIS		128 × 182	★	×	×	×
A6		105 × 148	☆	×	×	×
11" × 17"		279 × 432	☆	×	⊙	×
Legal (LG, 8 <sup>1</sup> / <sub>2</sub> " × 14")		216 × 356	☆	×	⊙	×
Letter (LT, 8 <sup>1</sup> / <sub>2</sub> " × 11")		216 × 279	☆	×	⊙	×
		279 × 216	☆	×	⊙	×
5 <sup>1</sup> / <sub>2</sub> " × 8 <sup>1</sup> / <sub>2</sub> "		140 × 216	☆	×	×	×

	Feed direction	Size (mm)	Bypass Tray	Paper Tray (Tray 1)	Paper Feed Unit (Tray 2/3/4)	2000-sheet Large Capacity Tray
Executive (Exec., 7 <sup>1</sup> / <sub>4</sub> " × 10 <sup>1</sup> / <sub>2</sub> " )		184 × 276	☆	×	☆	×
		276 × 184	☆	×	×	×
Folio (8 <sup>1</sup> / <sub>4</sub> " × 13")		210 × 330	☆	×	☆	×
Foolscap (F4, 8 <sup>1</sup> / <sub>2</sub> " × 13")		216 × 330	☆	×	☆	×
F/GL (8" × 13")		203 × 330	☆	×	☆	×
Com#10 Env (4 <sup>1</sup> / <sub>8</sub> " × 9 <sup>1</sup> / <sub>2</sub> " )		104.8 × 241.3	☆	×	×	×
C5 Env (6.38" × 9.02")		162 × 229	☆	×	×	×
C6 Env (4.49" × 6.38")		114 × 162	☆	×	×	×
DL Env (4.33" × 8.66")		110 × 220	☆	×	×	×
Monarch Env (3 <sup>7</sup> / <sub>8</sub> " × 7 <sup>1</sup> / <sub>2</sub> " )		98.4 × 190.5	☆	×	×	×
Custom Size	-	-	★*	×	×	×
8K (10 <sup>1</sup> / <sub>2</sub> " × 15.35")		267 × 390	☆	×	☆	×
16K (7.68" × 10 <sup>1</sup> / <sub>2</sub> " )		195 × 267	☆	×	☆	×
		267 × 195	☆	×	☆	×

- means that the size is exclusive.
- ◎ means that the size is supported and the printer selects the paper size automatically.
- ☆ means that the size is supported but the paper size should be selected with the control panel.



- ★ means that the size is supported but the paper size should be set with the control panel as a custom size.
- ★\* means that the supported size is approximately 90 - 305 mm in width, and approximately 148 - 458 mm in length. The supported size may differ depending on the printer language you use. Set the custom size setting with the control panel.
- × means that the size is not supported.





## ❖ Input Paper Sizes (Inch version)

	Feed direction	Size (inch)	Bypass Tray	Paper Tray (Tray 1)	Paper Feed Unit (Tray 2/3/4)	2000-sheet Large Capacity Tray
11" × 17"		11" × 17"	☆	×	⊙	×
Legal (LG)		8½" × 14"	☆	×	⊙	×
Letter (LT)		8½" × 11"	☆	×	⊙	×
		11" × 8½"	☆	●	⊙	●
5½" × 8½"		5½" × 8½"	☆	×	×	×
Executive (Exec.)		7¼" × 10½"	☆	×	☆	×
		10½" × 7¼"	☆	×	×	×
A3		11.26" × 16.54"	☆	×	⊙	×
B4 JIS		10.12" × 14.33"	☆	×	☆	×
A4		8.26" × 5.83"	☆	×	☆	×
		5.83" × 8.26"	☆	×	⊙	×
B5 JIS		7.17" × 10.12"	☆	×	☆	×
		10.12" × 7.17"	☆	×	⊙	×
A5		5.83" × 8.26"	☆	×	×	×
		8.26" × 5.83"	☆	×	⊙	×



	Feed direction	Size (inch)	Bypass Tray	Paper Tray (Tray 1)	Paper Feed Unit (Tray 2/3/4)	2000-sheet Large Capacity Tray
B6 JIS	☐	5.04" × 7.17"	★	×	×	×
A6	☐	4.13" × 5.63"	☆	×	×	×
Folio	☐	8 <sup>1</sup> / <sub>4</sub> " × 13"	☆	×	☆	×
Foolscap F4	☐	8 <sup>1</sup> / <sub>2</sub> " × 13"	☆	×	☆	×
F/GL	☐	8" × 13"	☆	×	☆	×
Com#10 Env	☐	4 <sup>1</sup> / <sub>8</sub> " × 9 <sup>1</sup> / <sub>2</sub> "	☆	×	×	×
C5 Env	☐	6.38" × 9.02"	☆	×	×	×
C6 Env	☐	4.49" × 6.38"	☆	×	×	×
DL Env	☐	4.33" × 8.66"	☆	×	×	×
Monarch Env	☐	3 <sup>7</sup> / <sub>8</sub> " × 7 <sup>1</sup> / <sub>2</sub> "	☆	×	×	×
Custom Size	-	-	★*	×	×	×
8K	☐	10 <sup>1</sup> / <sub>2</sub> " × 15.35"	☆	×	☆	×
16K	☐	7.68" × 10 <sup>1</sup> / <sub>2</sub> "	☆	×	☆	×
	☐	10 <sup>1</sup> / <sub>2</sub> " × 7.68"	☆	×	☆	×

- means that the size is exclusive.
- ◎ means that the size is supported and the printer selects the paper size automatically.
- ☆ means that the size is supported but the paper size should be selected with the control panel.



- ★ means that the size is supported but the paper size should be set with the control panel as a custom size.
- ★\* means that the supported size is approximately 3.5 - 12 inch in width, and approximately 5.8 - 18 inch in length. The supported size may differ depending on the printer language you use. Set the custom size setting with the control panel.
- × means that the size is not supported.

### ❖ Paper weight and the maximum number of sheets

	Supported paper weight	Maximum number of sheets (plain paper) *1
Tray 1	60 - 105 g/m <sup>2</sup> (16 - 28 lb)	500 (80 g/m <sup>2</sup> , 20 lb)
Tray 2	60 - 105 g/m <sup>2</sup> (16 - 28 lb)	500 (80 g/m <sup>2</sup> , 20 lb)
Bypass Tray	52 - 162 g/m <sup>2</sup> (14 - 42 lb)	100 (80 g/m <sup>2</sup> , 20 lb)
PAPER FEED UNIT Type 3800C (500 × 1)	60 - 105 g/m <sup>2</sup> (16 - 28 lb)	500 (80 g/m <sup>2</sup> , 20 lb)
PAPER FEED UNIT Type 3800C (500 × 2)	60 - 105 g/m <sup>2</sup> (16 - 28 lb)	1000 (80 g/m <sup>2</sup> , 20 lb)
Paper Bank PS470 (2000-sheet Large Capacity Tray)	60 - 105 g/m <sup>2</sup> (16 - 28 lb)	2000 (80 g/m <sup>2</sup> , 20 lb)
SR770 (2 Tray Finisher)	60 - 105 g/m <sup>2</sup> (16 - 28 lb)	2000 (80 g/m <sup>2</sup> , 20 lb)

\*1 Confirm that the top of the stack is not higher than the limit mark inside the tray.



## ❖ Output Paper Sizes (Metric version)

	Feed direction	Size (mm)	Standard Tray	Output Tray	2 Tray Finisher	4-bin Mailbox
A3		297 × 420	○	○	○	○
B4 JIS		257 × 364	○	○	○	○
A4		210 × 297	○	○	○	○
		297 × 210	○	○	○	○
B5 JIS		182 × 257	○	○	○	○
		257 × 182	○	○	○	○
A5		148 × 210	○	○	×	○
		210 × 148	○	○	○	○
B6 JIS		128 × 182	○	○	×	×
A6		105 × 148	○	○	×	×
11" × 17"		279 × 432	○	○	○	○
Legal (LG, 8 <sup>1</sup> / <sub>2</sub> " × 14")		216 × 356	○	○	○	○
Letter (LT, 8 <sup>1</sup> / <sub>2</sub> " × 11")		216 × 279	○	○	○	○
		279 × 216	○	○	○	○
5 <sup>1</sup> / <sub>2</sub> " × 8 <sup>1</sup> / <sub>2</sub> "		140 × 216	○	○	×	×



	Feed direction	Size (mm)	Standard Tray	Output Tray	2 Tray Finisher	4-bin Mailbox
Executive (Exec., 7 <sup>1</sup> / <sub>4</sub> " × 10 <sup>1</sup> / <sub>2</sub> " )		184 × 276	○	○	○	○
		276 × 184	○	○	×	×
Folio (8 <sup>1</sup> / <sub>4</sub> " × 13")		210 × 330	○	○	○	×
Foolscap (F4, 8 <sup>1</sup> / <sub>2</sub> " × 13")		216 × 330	○	○	○	×
F/GL (8" × 13")		203 × 330	○	○	○	○
Com#10 Env (4 <sup>1</sup> / <sub>8</sub> " × 9 <sup>1</sup> / <sub>2</sub> " )		104.8 × 241.3	×	○	×	×
CA Env (6.38" × 9.02")		162 × 229	×	○	×	×
C6 Env (4.49" × 6.38")		114 × 162	×	○	×	×
DL Env (4.33" × 8.66")		110 × 220	×	○	×	×
Monarch Env (3 <sup>7</sup> / <sub>8</sub> " × 7 <sup>1</sup> / <sub>2</sub> " )		98.4 × 190.5	×	○	×	×
Custom Size	-	-	○	○	×	○
8K (10 <sup>1</sup> / <sub>2</sub> " × 15.35")		267 × 390	○	○	○	×
16K (7.68" × 10 <sup>1</sup> / <sub>2</sub> " )		195 × 267	○	○	○	○
		267 × 195	○	○	○	○

- ○ means that the size is supported.
- × means that the size is not supported.



## ❖ Output Paper Sizes (Inch version)

	Feed direction	Size (inch)	Standard Tray	Output Tray	2 Tray Finisher	4-bin Mailbox
11" × 17"		11" × 17"	○	○	○	○
Legal (LG)		8 <sup>1</sup> / <sub>2</sub> " × 14"	○	○	○	○
Letter (LT)		8 <sup>1</sup> / <sub>2</sub> " × 11"	○	○	○	○
		11" × 8 <sup>1</sup> / <sub>2</sub> "	○	○	○	○
5 <sup>1</sup> / <sub>2</sub> " × 8 <sup>1</sup> / <sub>2</sub> "		5 <sup>1</sup> / <sub>2</sub> " × 8 <sup>1</sup> / <sub>2</sub> "	○	○	×	×
Executive (Exec.)		7 <sup>1</sup> / <sub>4</sub> " × 10 <sup>1</sup> / <sub>2</sub> "	○	○	○	○
		10 <sup>1</sup> / <sub>2</sub> " × 7 <sup>1</sup> / <sub>4</sub> "	○	○	×	×
A3		11.26" × 16.54"	○	○	○	○
B4 JIS		10.12" × 14.33"	○	○	○	○
A4		8.26" × 5.83"	○	○	○	○
		5.83" × 8.26"	○	○	○	○
B5 JIS		7.17" × 10.12"	○	○	○	○
		10.12" × 7.17"	○	○	○	○
A5		5.83" × 8.26"	○	○	×	○
		8.26" × 5.83"	○	○	○	○
B6 JIS		5.04" × 7.17"	○	○	×	×



	Feed direction	Size (inch)	Standard Tray	Output Tray	2 Tray Finisher	4-bin Mailbox
A6		4.13" × 5.63"	○	○	×	×
Folio		8 <sup>1</sup> / <sub>4</sub> " × 13"	○	○	○	×
Foolscap F4		8 <sup>1</sup> / <sub>2</sub> " × 13"	○	○	○	×
F/GL		8" × 13"	○	○	○	○
Com#10 Env		4 <sup>1</sup> / <sub>8</sub> " × 9 <sup>1</sup> / <sub>2</sub> "	×	○	×	×
C6 Env		4.49" 6.38"	×	○	×	×
C5 Env		6.38" × 9.02"	×	○	×	×
DL Env		4.33" × 8.66"	×	○	×	×
Monarch Env		3 <sup>7</sup> / <sub>8</sub> " × 7 <sup>1</sup> / <sub>2</sub> "	×	○	×	×
Custom Size	-	-	○	○	×	○
8K		10 <sup>1</sup> / <sub>2</sub> " × 15.35"	○	○	○	×
16K		7.68" × 10 <sup>1</sup> / <sub>2</sub> "	○	○	○	○
		10 <sup>1</sup> / <sub>2</sub> " × 7.68"	○	○	○	○

- means that the size is supported and that the paper size should be set with the control panel. There is no dial in the tray.
- × means that the size is not supported.



---

## Paper Recommendations

---

---

### Loading Paper

---

#### Important

- Do not use paper that is meant for an ink-jet printer or it may stick to the Fusing Unit and cause a paper misfeed.
- When printing on an OHP transparency that has a print side, load it with the print side up on the Bypass Tray. Not taking this precaution may cause it to stick to the Fusing Unit and cause a misfeed.
- Print quality cannot be guaranteed if recommended paper is not used. For details about recommended paper, contact your sales or service representative.
- Do not use paper that has already been printed onto by other printers.

---

### Storing Paper

---

- Paper should always be stored properly. Improperly stored paper might result in poor print quality, paper misfeeds, or printer damage. Recommendations are as follows:
  - Avoid storing paper in humid areas.
  - Avoid exposing paper to direct sunlight.
  - Store on a flat surface.
- Keep open reams of paper in the package in which the paper came.

---

## Types of Paper and Other Media

---

### ❖ Plain Paper

- Tray 1/2 can hold up to 500 sheets.  
PAPER FEED UNIT Type 3800C (500x1) can hold up to 500 sheets.  
PAPER FEED UNIT Type 3800C (500x2) can hold up to 1000 sheets.  
Paper Bank PS470 can hold up to 2000 sheets.  
Confirm that the top of the stack is not higher than the limit mark inside the tray.
- Bypass Tray supports sizes approximately 3.5 - 12 inch in width and approximately 5.8 - 18 inch in length.
- When printing on the reverse side of plain paper that is already printed on, you should load it on the Bypass Tray and select **[Plain (Duplex Backside)]** from **[Paper Type:]** with the printer driver.

### ❖ Thick Paper

- Use the Bypass Tray.
- The Bypass Tray can hold paper up to 135 kg (163 g/m<sup>2</sup>) in weight. The print quality on paper that is thicker cannot be guaranteed.
- Confirm that the top of the stack is not higher than the limit mark inside the tray.
- When printing on thick paper, select thick paper mode with the printer driver.
- When printing on the reverse side of plain paper that is already printed on, you should load it on the Bypass Tray and select **[Thick (Duplex Backside)]** from **[Paper Type:]** with the printer driver.



#### Note

- ❑ The number of sheets that can be set varies depending on the paper thickness and paper type.



### ❖ OHP transparencies

- When printing on OHP transparencies, use the Bypass Tray.
- Load OHP transparencies on the tray with the print side up or they may stick to the Fusing Unit and cause a misfeed.
- Remove any unused OHP transparencies from the Bypass Tray after you are finished printing. Leaving them in the tray may cause them to stick together.
- When printing on OHP transparencies, you should select the OHP transparency mode with the printer driver.
- Confirm that the top of the stack is not higher than the limit mark inside the tray.
- When you print more than one OHP transparency, remove each sheet from the tray before the next sheet is printed out, or select "Slip Sheet" in the printer driver. For details about using "Slip Sheet", see the printer driver Help file.



## ❖ Envelopes

### Important

- Only envelopes ① and ② as shown below are supported.

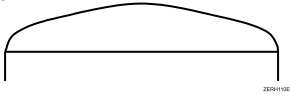
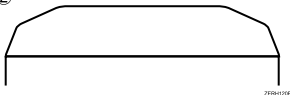
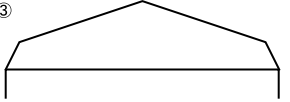
<p>①</p> 	<p>Supported *1</p>
<p>②</p> 	<p>Supported *1</p>
<p>③</p> 	<p>Not supported</p>

\*1 Misfeeds also might occur when using envelopes ① and ② depending on the length and shape of the flaps.

- When printing on envelopes, use the Bypass Tray, and select "Thick Paper" as the paper type in the "Tray Paper Settings" menu on the control panel. See p.43 "Specifying a paper type for the Bypass Tray".
- Specifications of envelopes are as follows:

	Metric version	Inch version
Weight	72 - 90 g/m <sup>2</sup>	19 - 24 lb
Recommended weight and size	72 g/m <sup>2</sup> , 114 × 162 mm (C6 Env)	24 lb, 3 <sup>7</sup> / <sub>8</sub> " × 7 <sup>1</sup> / <sub>2</sub> " (Monarch)

- You can load up to 10 envelopes (72 - 92 g/m<sup>2</sup>, 19 - 24 lb) in the Bypass Tray at the same time, without forcibly pressing them. Confirm that the envelopes are not damp and that the top of the stack is not higher than the limit mark on the side guide.
- Confirm that the print side is facing up when loading onto the Bypass Tray.
- When loading envelopes, be sure to unfold the flaps and position them opposite to the paper feed direction.

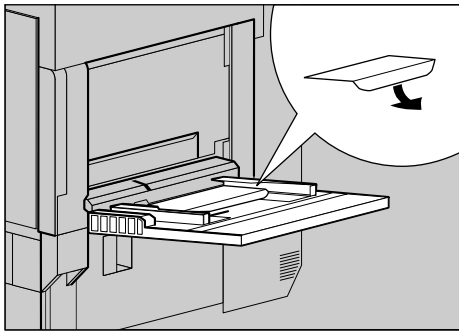

ZGBH020N

- Make the printer driver's setting for rotating the print image by 180 degrees. For details, see the Help file for the printer driver.
- Confirm that there is no air in the envelopes before loading.
- To get better print quality, it is recommended that you set the right, left, top, and bottom print margin to at least 15 mm (0.6").
- Do not print on both sides of envelopes.
- Load only one size and type of envelope at the same time.
- Before loading envelopes, flatten their leading edges (the side being fed into the printer) by running a pencil or ruler across them.
- Before loading envelopes, confirm that they are rectangular in shape.
- The supported size of envelopes is listed in "*Paper and Other Media*" in Maintenance Guide 2.



❖ **Paper not supported by this printer**

Avoid using the following types of paper that are not supported by this printer:

- Paper meant for an ink-jet printer
- Bent, folded, or creased paper
- Curled or twisted paper
- Torn paper
- Wrinkled paper
- Damp paper
- Paper that is dry enough to emit static electricity
- Paper that has already been printed onto, except a preprinted letterhead
- Coated paper
- Special paper, such as thermal paper, aluminum foil, carbon paper and conductive paper
- Paper whose weight is heavier or lighter than the limitation
- Paper with windows, holes, perforations, cutouts, or embossing
- Label paper on which glue or base paper is exposed
- Paper with clips or staples





## Printable Area

The following shows the printable area for this printer. Be sure to set the print margins correctly by the application.

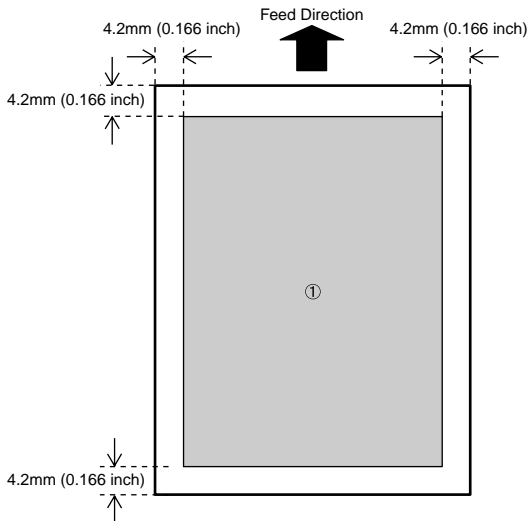

① : Printable area

 **Note**

- The printable area may vary depending on the paper size, printer language and printer driver settings.





## Loading Paper

Load paper and change the paper size in Tray 1, Tray 2 and the optional Paper Feed Unit by following the procedures below.

### Important

- Tray 1 uses  $11 \times 8 \frac{1}{2}$  paper exclusively. Load only  $11 \times 8 \frac{1}{2}$  paper at all times.
- 2000-sheet Large Capacity Tray uses  $11 \times 8 \frac{1}{2}$  paper exclusively. Load only  $11 \times 8 \frac{1}{2}$  paper at all times.
- If you want to load A4 paper in Tray 1 and optional 2000-sheet Large Capacity Tray, contact your sales or service representative.

### Reference

See p.12 “Paper Sizes” concerning paper to be loaded in the paper tray and optional Paper Feed Unit.

## Loading Paper in Tray 1

### Important

- Tray 1 uses  $11 \times 8 \frac{1}{2}$  paper exclusively. Load only  $11 \times 8 \frac{1}{2}$  paper at all times.
- If you want to load A4 paper in Tray 1, contact your sales or service representative.

**1** Pull out the paper tray slowly until it stops.

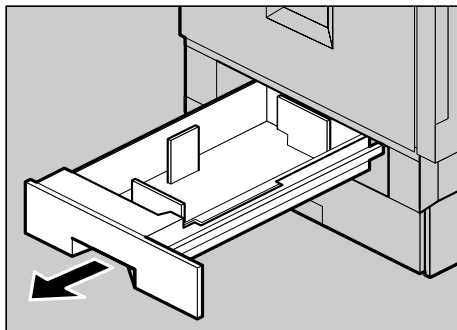

ZDJH003J



- 2** Load paper into the tray with the print side down.

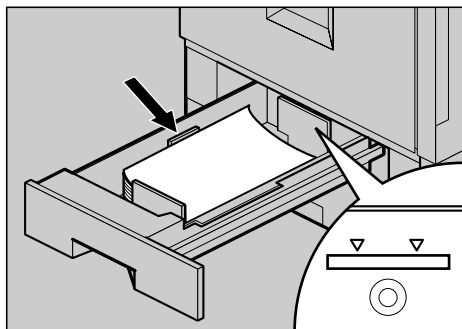

ZDJY001J

**Important**

- Confirm that the top of the stack is not higher than the limit mark inside the tray.

- 3** Carefully slide the paper tray into the printer until it stops.

## Loading Paper in Tray 2 and the Optional Paper Feed Unit

This section describes loading paper which is different from default size in Tray 2.

- 1** Pull out the paper tray slowly until it stops.

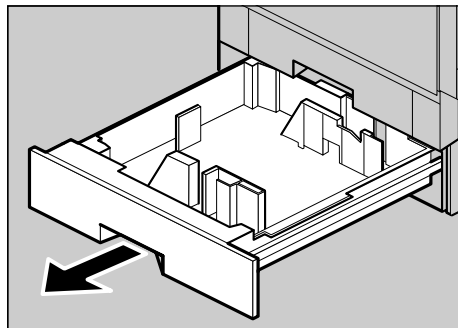

ZDJH005J



- 2** Set the paper guide lock to the "unlocked" position.

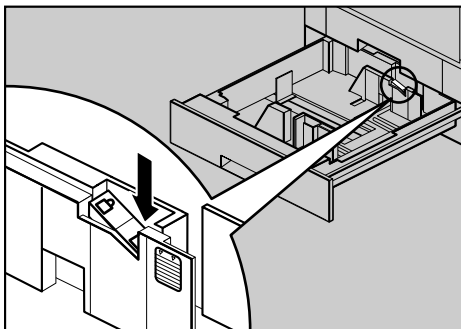

ZDJY003J

- 3** Pushing the green lever of the side guide (①), move the side guide toward you to open it (②).

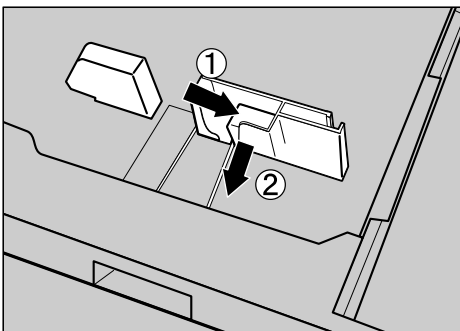

ZDJY802J

- 4** Pinching both sides of the end guide (①), move the end guide in the direction of the arrow to open it.

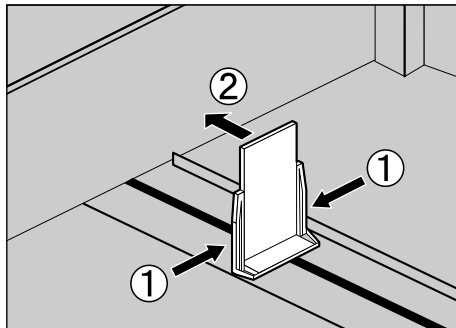

ZDJY801J

- 5** Load paper in the same direction.

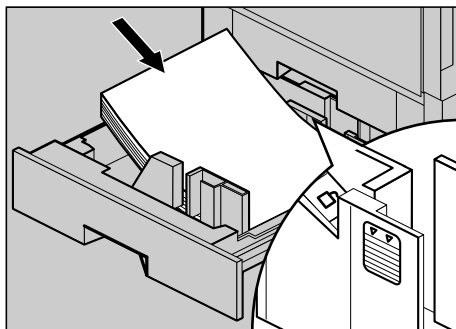

ZDJY002J

**Important**

- ❑ Confirm that the top of the stack is not higher than the limit mark inside the tray.





- 6** Pushing the green lever of the side guide (①), move the side guide toward the paper stack until it stops (②).

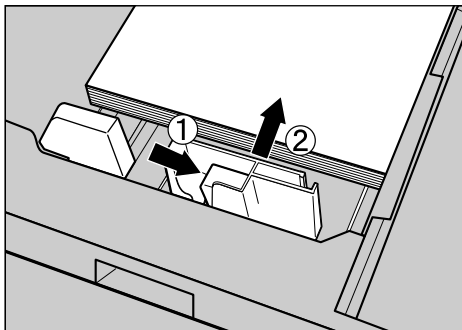

ZDJY006J

- 8** Pinching both sides of the end guide (①), move the end guide toward the paper stack until it stops (②).

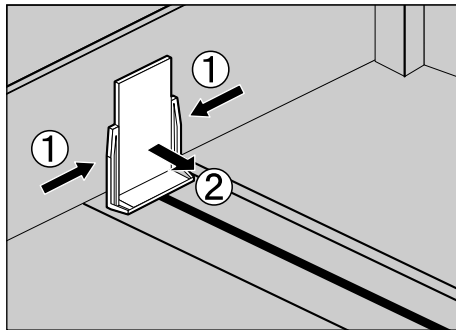

ZDJY005J

- 7** Make sure the paper is fixed in place, and then lock the side guide.

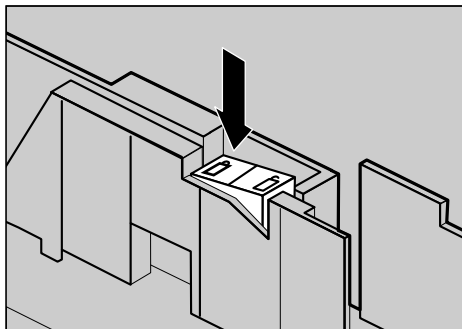

ZDJY007J

- 9** Carefully slide the paper tray into the printer until it stops.



**Important**

- Do not slide the paper tray in with force. If you do, the front and side guides might move.



## Loading paper in Paper Bank PS470 (2000-sheet Large Capacity Tray)

### Important

- 2000-sheet Large Capacity Tray uses 11 × 8 1/2  paper exclusively. Load only 11 × 8 1/2 paper at all times.
- If you want to load A4  paper in the 2000-sheet Large Capacity Tray, contact your sales or service representative.

**1** Pull out the paper tray slowly until it stops.

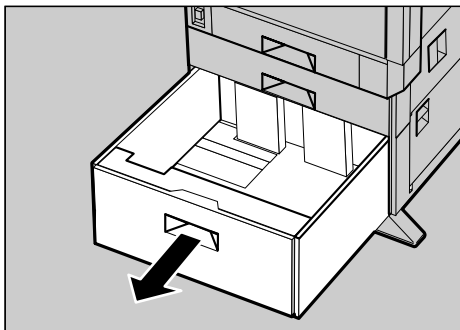

ZDJY008J

**2** With the print side down, align all four sides of two paper stacks, and then load them next to each other in the tray. Each side has a limit of 1,000 sheets.

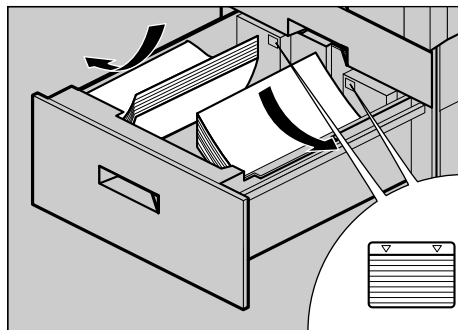

ZDJY008J





### Important

- Align the paper stacks and load them against the left and right walls, or a paper misfeed might occur.
- Confirm that the top of the stack is not higher than the limit mark inside the tray.

**3** Push in the paper tray slowly until it stops.

## If you load a paper size that is not selected automatically



### Note

- Paper sizes that are not selected automatically are Paper sizes that are not selected automatically are B4 , A4 , B5 ,  $7\frac{1}{4} \times 10\frac{1}{2}$  ,  $8 \times 13$  ,  $8\frac{1}{2} \times 13$  ,  $8\frac{1}{4} \times 13$  , 8K ( $10\frac{1}{2} \times 15.35$ ) , 16K ( $7.68 \times 10\frac{1}{2}$ ) , 16K ( $10\frac{1}{2} \times 7.68$ ) .

### Reference

See p.31 “Loading Paper in Tray 2 and the Optional Paper Feed Unit” for details about how to load the paper.

### Important

- Tray 1 uses  $11 \times 8\frac{1}{2}$   paper exclusively. Load only  $11 \times 8\frac{1}{2}$  paper at all times.
- Paper Bank PS470 uses  $11 \times 8\frac{1}{2}$   paper exclusively. Load only  $11 \times 8\frac{1}{2}$  paper at all times.
- If you want to load A4  paper in Tray 1 and optional Paper Bank PS470, contact your sales or service representative.

- 1 Press the **[User Tools/Counter]** key.

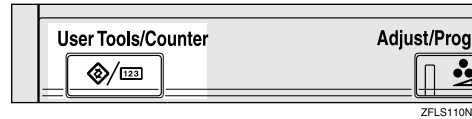

- 2 Press **[System Settings]**.

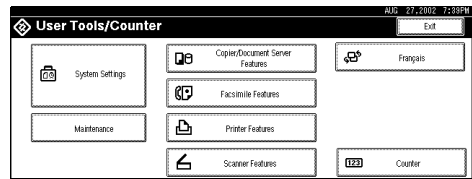

- 3 Press **[Tray Paper Settings]**.

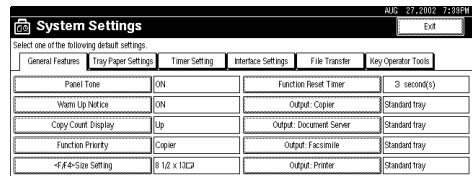



**4** Select the tray for which you want to change the paper settings.

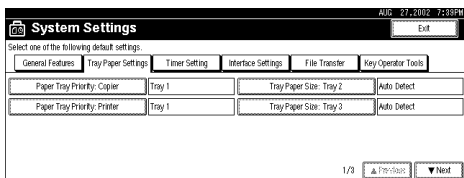

**Note**

When the optional paper trays are installed, [Tray Paper Size: Tray 3] and [Tray Paper Size: Tray 4] are displayed.

- ① When the PAPER FEED UNIT Type 3800C (500 × 2) is installed
- ② When the PAPER FEED UNIT Type 3800C (500 × 1) is installed
- ③ When the Paper Bank PS470 (2000-sheet Large Capacity Tray) is installed

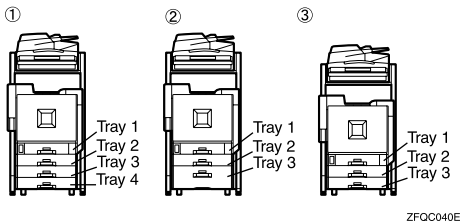

ZFQC040E

**5** Select the loaded paper size and feed direction, and then press [OK].

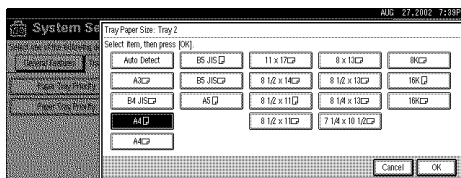

The set paper size and feed direction is displayed.

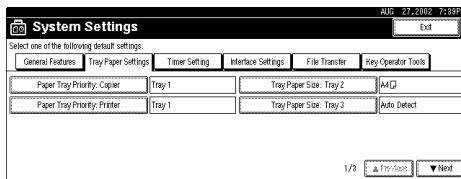

**6** Press the [User Tools/Counter] key.

The initial display is shown.

**Important**

If you want to print on paper that is selected automatically after printing on paper with a size that is not selected automatically, you must return the setting to "Auto Detect". Reload the paper, repeat to step 1 to 4, and select "Auto Detect" in step 5. The setting is returned to "Auto Detect".



## Changing the paper type

By selecting the paper type you want to load, the printer can perform printing better. You can select from the following paper types.

- Plain Paper, Recycled Paper, Special Paper, Color Paper, Letterhead Paper, Preprinted Paper, Prepunched Paper, Bond Paper, Card Stock

### Important

- The paper type setting in the printer driver takes priority over the setting on the control panel.

### 1 Press the **[User Tools/Counter]** key.



### 2 Press **[System Settings]**.

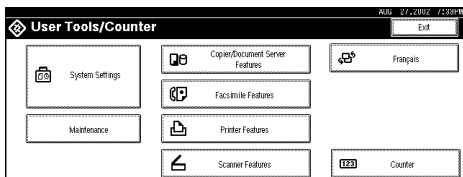

### 3 Press **[Tray Paper Settings]**.

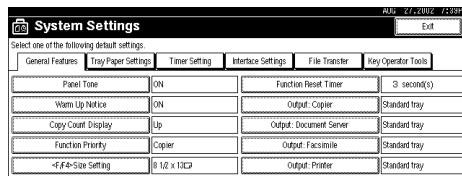

### 4 Press **[▼Next]**.

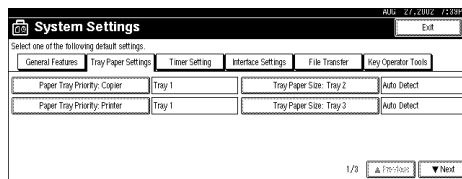

### 5 Select the tray for which you want to change the paper settings.

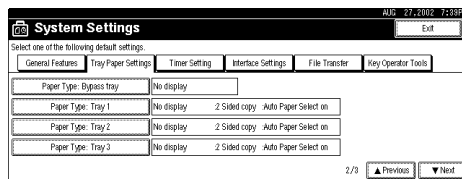

### Note

- When the optional paper trays are installed, **[Tray Paper Size: Tray 3]** and **[Tray Paper Size: Tray 4]** are displayed.

## 6 Select the paper type and the copying method in duplex.

### 1 Select the paper type

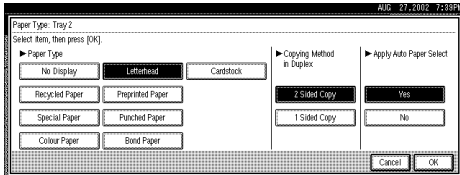

### 2 Specify the copying method in duplex.

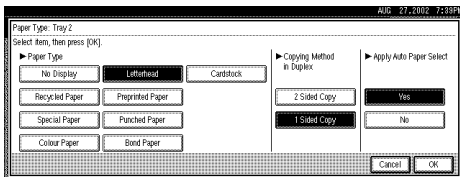

### 3 Specify whether you want to apply auto paper selection.

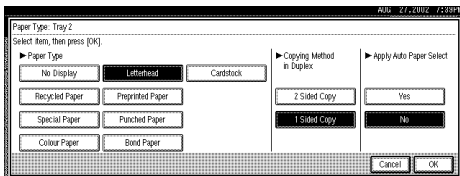

### 4 Press [OK].

The specified paper setting is displayed.

## 7 Press the [User Tools/Counter] key.

The initial display is shown.

## Loading Paper in the Bypass Tray

Besides regular paper, you can load paper onto the Bypass Tray which cannot be loaded in the Paper Tray or Paper Feed Unit such as thick paper, envelopes, OHP transparencies, and paper that is longer than A3.

### Note

- Paper sizes supported by the Bypass Tray are 90 - 305 mm in width and 148 - 457 mm in length.
- If you load custom size paper or special paper, select the paper size with the control panel. The RPCS printer driver can select the paper size with the printer driver properties. The paper size selected with the printer driver overrides the one selected with the control panel. See [p.41 "Specifying a custom paper size for the Bypass Tray"](#).
- If you load thick paper, OHP transparencies, or envelopes, make the settings for thick paper or OHP transparencies with the control panel or printer driver. See [p.43 "Specifying a paper type for the Bypass Tray"](#).
- The number of pages that can be loaded in the Bypass Tray differs depending on the paper type. Confirm that the top of the stack is not higher than the limit mark inside the tray.



**! Limitation**

- ❑ You cannot use the following functions when printing on paper that is loaded in the Bypass Tray.
  - Duplex Print
  - Collate, Job Separation
  - Staple/Punch
  - Auto Tray Select

**1** Open the Bypass Tray.

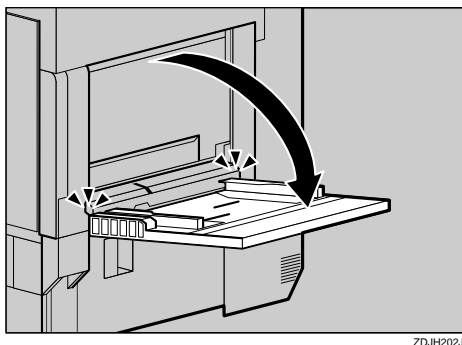

**✎ Note**

- ❑ If you load A4 or larger size paper, pull out the Bypass Tray extension, and then flip it open.

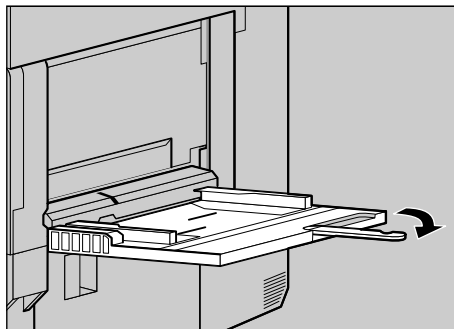

**2** Slide the side guides outward (①), and then load paper until it stops with the print side up (②).

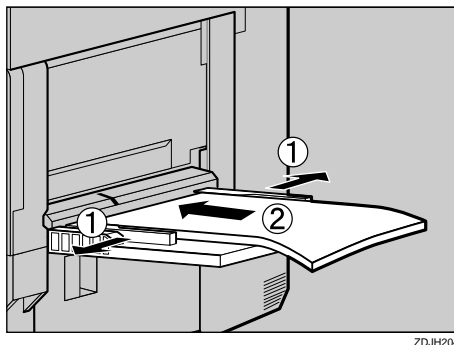



**3** Adjust the side guides to the paper width.

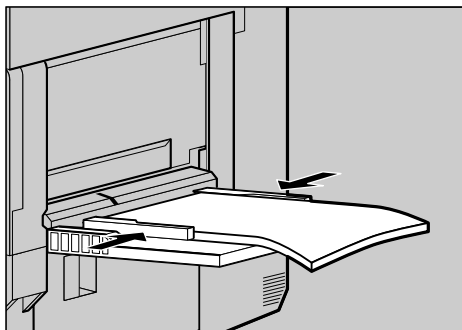

ZD.JH205J

**Important**

- Confirm that the top of the stack is not higher than the limit mark inside the tray.
- Shuffle the paper before loading the stack onto the tray so multiple sheets are not fed in at one time.

**4** Set the paper size using the control panel as follows:

**1** Press the **[User Tools/Counter]** key.

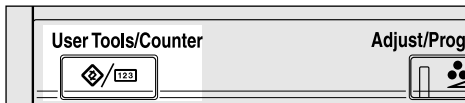

ZFLS110N

**2** Press **[Printer Features]**.

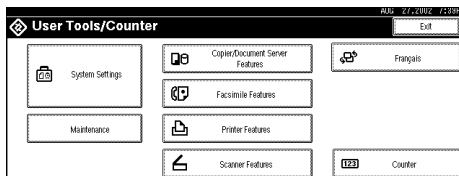

**3** Press **[Paper Input]**.

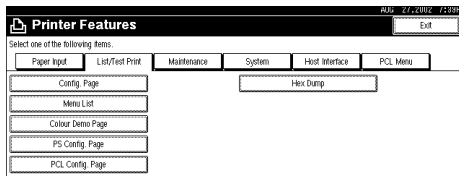

**4** Press **[Bypass Paper Size]**.

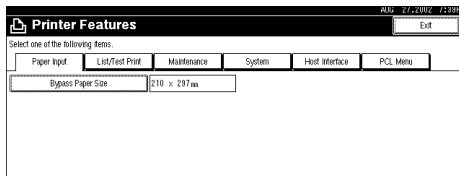



- 5 Select the loaded paper size and feed direction, and then press [OK].

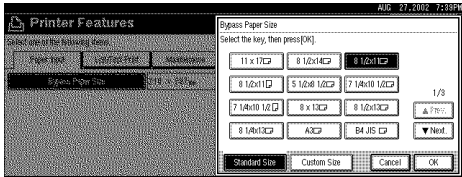

The set paper size and feed direction is displayed.

- 6 Press the [User Tools/Counter] key.

The initial display is shown.

- 1 Press the [User Tools/Counter] key.

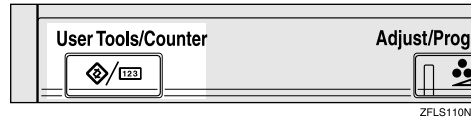

- 2 Press [Printer Features].

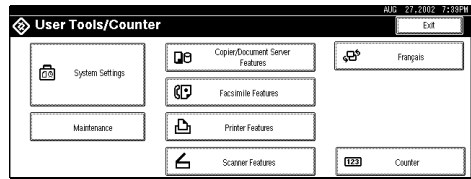

- 3 Press [Paper Input].

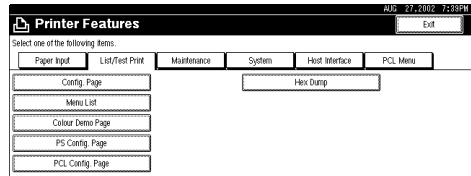

- 4 Press [Bypass Paper Size].

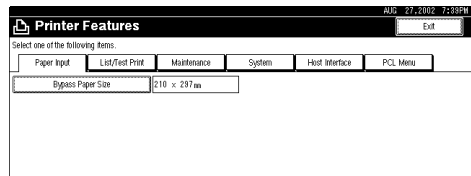

## Specifying a custom paper size for the Bypass Tray

### Important

- The paper size selected with the printer driver overrides the one selected with the control panel. You do not have to make settings with the control panel if you already made them with the printer driver. However, when printing with a printer driver other than the RPCS printer driver, you must make the settings using the control panel. For more information about the printer driver, see the Help Files.
- The printer cannot print from applications that do not support custom paper size.

**5** Press [Custom Size].

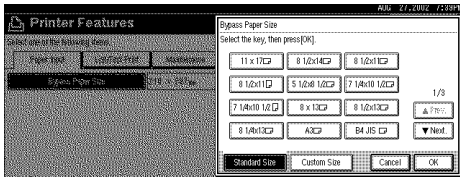

**6** Enter the paper size.

- 1 Enter the vertical size of the paper in [Vert.] with the number keys, and then press [#].

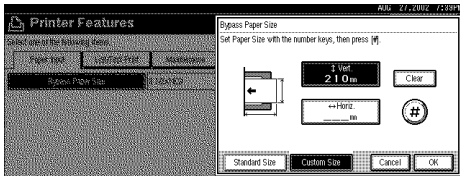

**Note**

- When [Horiz.] is highlighted, press [Vert.] to highlight [Vert.], and then you can enter the value.
- If you want to clear the displayed value, press [Clear].

- 2 Enter the horizontal size of the paper in [Horiz.] with the number keys, and then press [#].

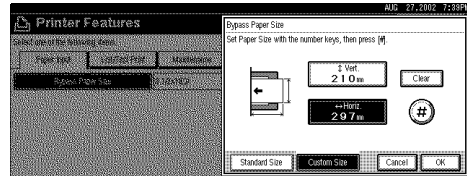

**Note**

- When [Vert.] is highlighted, press [Horiz.] to highlight [Horiz.], and then you can enter the value.

- 3 Press [OK].

The set paper size is displayed.

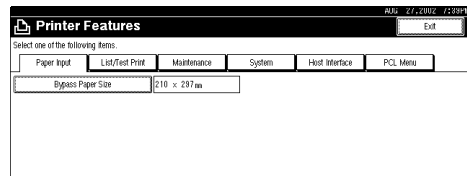

- 7 Press the [User Tools/Counter] key.

The initial display is shown.



## Specifying a paper type for the Bypass Tray

By selecting the paper type you want to load, the printer can perform printing better. You can select from the following paper types.

- Plain Paper, Recycled Paper, Special Paper, Color Paper, Letterhead, Preprinted, Pre-punched, Labels, Bond Paper, Card Stock, OHP Transparencies, Thick Paper, Plain Paper (Duplex), Thick Paper (Duplex)

### Important

- Be sure to select the paper type when you load labels, thick paper, or OHP transparencies in the Bypass Tray.

### Limitation

- You cannot use the following functions when printing on paper loaded in the Bypass Tray.
  - Duplex Print
  - Collate, Job Separation
  - Staple, Punch
  - Auto Tray Select

- 1 Press the **[User Tools/Counter]** key.

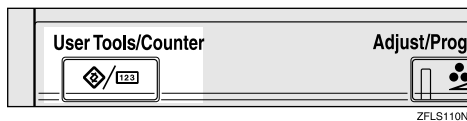

- 2 Press **[System Settings]**.

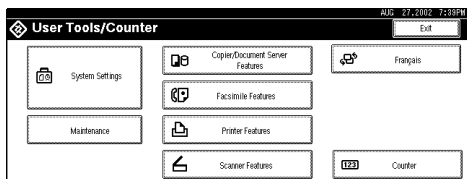

- 3 Press **[Tray Paper Settings]**.

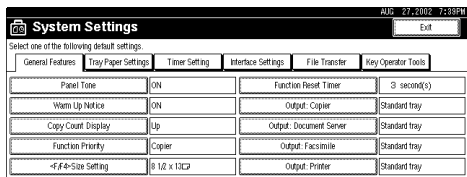

- 4 Press **[▼Next]**.

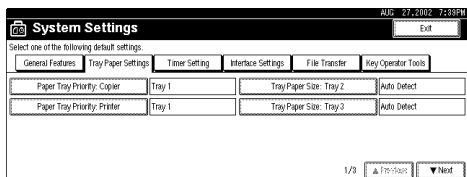



## 5 Press [Paper Type: Bypass Tray].

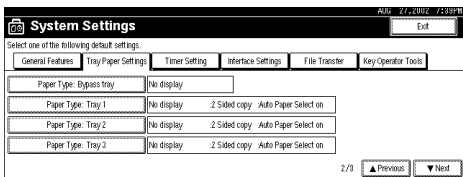

## 6 Select the paper type, and then press [OK].

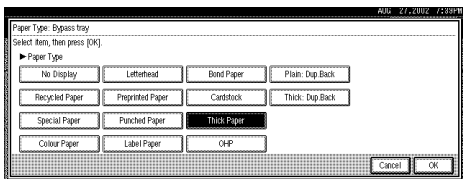

The specified paper setting is displayed.

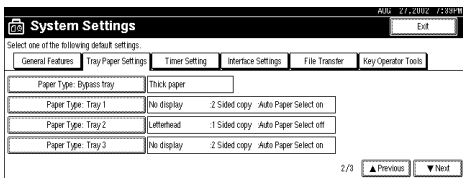

## 7 Press the [User Tools/Counter] key.

The initial display is shown.



## 3. Troubleshooting

### Error & Status Messages on the Control Panel

#### ❖ Status Messages

Messages	Description	Solution
Color is being adjusted	The printer is calibrating the color.	Wait for a while.
Hex Dump Mode	In Hex Dump Mode	No action required.
Initializing Unit	The printer is initializing the development unit.	Wait for a while. Do not turn the main power switch off while the machine is being initializing.
Loading Toner...	The printer is loading the toner.	Wait for a while.
Offline	The printer is offline and cannot print data.	Press <b>【OnLine】</b> .
Please wait	The printer is warming up or loading the toner.	Wait until the printer signals Ready.
Printing...	The printer is doing print job.	Wait for a while.
Ready	The default ready message. The printer is ready to use.	No action required.
Resetting job...	Job is being reset.	Wait for a while.
Waiting...	The printer is waiting for the next data to print.	Wait for a while.



## ❖ Alert Messages

Messages	Description	Solution
Add Toner No toner. Open the cover as shown and replace Toner Cartridge by following instructions shown inside the cover.	The indicated toner cartridge(s) is/are empty.	Replace the indicated toner cartridge(s). See "Replacing Consumables and Maintenance Kit" in Maintenance Guide 1.
Cannot communicate with external server. Contact key operator.	There is a problem with the Network settings.	Connect the machine to the Network correctly, and then make sure the server's power switch is on. If the message appears again, contact your key operator, sales or service representative.
Cannot connect with network. Check settings of IP Address.	There is a problem with the Network settings.	Set a IP address correctly. See "Configuring the Network with the Control Panel" in Administrator Reference 1. If the message appears again, contact your sales or service representative.
Cannot connect with network. Contact key operator.	There is a problem with the Network settings.	Connect the machine to the Network correctly, and confirm other device's power switch is turned on. If the message appears again, contact your sales or service representative.
Cannot print file stored in PC. Load paper on #.	The paper in tray # ran out while stored files were being printed. #: tray number	Load paper in tray #.



Messages	Description	Solution
Close duplex unit cover.	The cover of the Duplex Reversal Unit is open.	Close the cover of the Duplex Reversal Unit.
Collate has been cancelled.	The setting of collate has been cancelled.	Turn the main power switch off and then on. If the message appears again, contact your sales or service representative.   <b>Reference</b> Before turning the main power switch, see "Turning Off the Main Power" in Administrator Reference 1.
Development Unit Setting Error Development Units are not set properly: Black, Yellow, Magenta, Cyan Open the part as shown and set the unit.	The indicated development Unit(s) is/ are not set correctly, or is not set.	Set the indicated Development Unit(s) correctly. See "Replacing Consumables and Maintenance Kit" in Maintenance Guide 1.
Duplex has been cancelled.	The setting of duplex print has been cancelled.	To print the image correctly, add memory to the printer. Be sure to use the correct paper.
Duplex mode is in off position for tray #. Select another tray from followings and press <b>[Continue]</b> . To cancel job, press <b>[Reset]</b> . Tray setting can also be changed in User Tools. Required:<xxx> <yyy>	The machine sets duplex mode off for the tray # that the printer driver has set the mode on. #: tray number <xxx>: paper size <yyy>: paper type	Set the tray setting correctly.



Messages	Description	Solution
Exceeded max. pages. Collate is incomplete.	The printer identified a collation page overflow error.	Increase the RAM capacity.
		Install the optional hard disk drive.
Exceeded max. stored pages in sample print and locked print.	The maximum number of stored files has been exceeded during Sample Print or Locked Print.	Reduce the number of pages to print.
Finisher is in use for another function. Please wait.	Optional 2 Tray Finisher is in use for another function.	Wait until the job will be completed.
Following output tray is full. Remove the paper.	The indicated output tray is full.	Remove paper from the output tray.
Function Problem Following unit is out of order. Press <b>[Cancel]</b> to cancel functions. Please call service.	There is a problem with the unit indicated in the panel display.	Turn the main power switch off and then on. If the message appears again, contact your sales or service representative.   <b>Reference</b> Before turning the main power switch, see "Turning Off the Main Power" in Administrator Reference 1.





Messages	Description	Solution
Function Problem Functional problem within the Copier Turn main power switch off then on. If the error appears again, call service.	There is a problem with the machine in the location indicated on the panel display.	Turn the main power switch off, and then on five seconds later. If the message appears again, contact your sales or service representative.   <b>Reference</b> Before turning the main power switch, see "Turning Off the Main Power" in Administrator Reference 1.
Fusing Oil Unit Replacement Fusing oil is empty. Open the part as shown and replace Fusing Oil Unit.	It is time to replace the fusing oil unit.	Replace a fusing oil unit. Depending on your service contract, contact your sales or service representative.  See "Replacing Consumables and Maintenance Kit " in Maintenance Guide 1.
Fusing Oil Unit Setting Error Fusing Oil Unit is not set properly. Open the part as shown and set the unit.	The fusing oil unit is not set correctly, or is not set.	Set the fusing oil unit correctly. See "Replacing Consumables and Maintenance Kit" in Maintenance Guide 1.
Fusing Unit Replacement Replacement of Fusing Unit is required. Open the part as shown and replace the unit.	It is time to replace the fusing unit.	Replace a fusing unit. Depending on your service contract, contact your sales or service representative.  See "Replacing Consumables and Maintenance Kit " in Maintenance Guide 1.



Messages	Description	Solution
Fusing Unit Setting Error Fusing Unit is not set properly. Open the part as shown and set the unit.	The fusing unit is not set correctly, or is not set.	Set the fusing unit correctly. See "Replacing Consumables and Maintenance Kit" in Maintenance Guide 1.
Hard disk is full. Delete unnecessary files.	The maximum Hard disk drive area size has been exceeded.	Delete the unnecessary stored file.
Hole punch receptacle is full. Empty it.	The punch waste box is full of punch chips.	Remove the punch chips from the punch waste box. See p.92 "Removing Punch-hole Chips". When the message appears even the waste box is not full, remove the Punch- hole chips on the top of the punch waste box. See p.93 "When the message appears even after removing the Punch-hole chips".



Messages	Description	Solution
LCT has a problem. Turn Main Power Switch off then on. If the error appears again, call service representative.	The LCT (Large Capacity Tray) is malfunctioning.	Turn the main power switch off and then on. If the message appears again, contact your sales or service representative.   <b>Reference</b> Before turning the main power switch, see "Turning Off the Main Power" in Administrator Reference 1.
Load following paper in Tray #, or select another tray and press <b>[Continue]</b> . To cancel job, press <b>[Reset]</b> . Required:<xxx> <yyy>	The indicated paper input tray is out of paper. #: tray number <xxx>: paper size <yyy>: paper type	Load paper into the indicated paper input tray.
NV-RAM has a problem.	The printer identified a memory switch (User Account Enhance Unit) error.	Replace the User Account Enhance Unit.
Original Misfeed Original was misfed at following point. Open the part as shown, then remove it.	There is a misfeed in the indicated point.	Remove the misfed paper. See p.68 "Removing Misfed Paper".
Output tray has been changed.	The output tray has been changed because the selected output tray cannot handle the paper size in use.	Set the correct output tray.



Messages	Description	Solution
Paper in duplex unit. Open cover and remove paper.	There is a misfeed in the Duplex Reversal Unit.	Remove misfed paper. See p.81 “When “Paper Misfeed: Z1” Appears”.
Paper in staple tray. Open finisher cover and remove paper.	There is a misfeed in the optional 2 Tray Finisher.	Open the finisher cover and remove misfeed. See p.76 “When “Paper Misfeed: R” Appears”.
Paper Misfeed Paper was misfed at following point. Open the part as shown and remove it.	There is a misfeed in the indicated point.	Remove misfed paper. See p.68 “Removing Misfed Paper”.
Paper remains on staple tray. Remove it.	There is still paper in the staple tray.	Remove paper from the staple tray.
Paper size and type are mismatched. Select another tray from followings and press <b>[Continue]</b> . To cancel job, press <b>[Reset]</b> . Paper size and type can also be changed in User Tools. Required:<xxx> <yyy>	The paper size and the paper type settings of the input paper tray are not the same as those of the tray selected by the printer driver, when Auto Tray Select feature is on. <xxx>: paper size <yyy>: paper type	Load the required paper size and type into the paper input tray.



Messages	Description	Solution
<p>Paper size and type of tray # are mismatched.</p> <p>Select another tray from followings and press <b>[Continue]</b>. To cancel job, press <b>[Reset]</b>. Paper size and type can also be changed in User Tools.</p> <p>Required:&lt;xxx&gt; &lt;yyy&gt;</p>	<p>The paper size and the paper type settings of the input paper tray are not the same as those of the printer driver.</p> <p>#: tray number &lt;xxx&gt;: paper size &lt;yyy&gt;: paper type</p>	<p>Load the required paper size and type into the paper input tray #.</p>
<p>Paper size of Tray # is mismatched.</p> <p>Select another tray from followings and press <b>[Continue]</b>. To cancel job, press <b>[Reset]</b>. Paper size can also be changed in User Tools.</p> <p>Required:&lt;xxx&gt; &lt;yyy&gt;</p>	<p>The paper size settings of the input paper tray is not the same as those of the printer driver.</p> <p>#: tray number &lt;xxx&gt;: paper size &lt;yyy&gt;: paper type</p>	<p>Load the required paper size into the paper input tray #.</p>
<p>Paper type of Tray # is mismatched.</p> <p>Select another tray from followings and press <b>[Continue]</b>. To cancel job, press <b>[Reset]</b>. Paper type can also be changed in User Tools.</p> <p>Required:&lt;xxx&gt; &lt;yyy&gt;</p>	<p>The paper type settings of the input paper tray is not the same as those of the printer driver.</p> <p>#: tray number &lt;xxx&gt;: paper size &lt;yyy&gt;: paper type</p>	<p>Load the required paper type into the paper input tray #.</p>
<p>Parallel I/F board has a problem.</p>	<p>There is a problem with the parallel interface.</p>	<p>If you use the parallel I/F, replace the interface cable that caused the error. If the message appears again, contact your sales or service representative.</p>



Messages	Description	Solution
Photoconductor Units Setting Error Photoconductor Units are not set properly: Black, Yellow, Magenta, Cyan Open the part as shown and set the unit.	The indicated Photoconductor Unit(s) is/ are not set correctly, or is not set.	Set the indicated Photoconductor Unit(s) correctly. See "Replacing Consumables and Maintenance Kit" in Maintenance Guide 1.
Problem with the hard disk. Call service.	The printer identified a hard disk drive error.	Turn the main power switch off and then on. If the message appears again, contact your sales or service representative.   <b>Reference</b> Before turning the main power switch, see "Turning Off the Main Power" in Administrator Reference 1.
Problem with IEEE 1394 board. Call service.	The printer identified an IEEE1394 Board error.	Contact your sales or service representative.
Problem with the printer module. Call service.	The printer identified a DIMM sum value error.	Contact your sales or service representative.
Punch has been cancelled.	The setting of punch function has been cancelled.	Verify that the paper orientation, paper feed direction and the setting of punch where you desire.



Messages	Description	Solution
Replacement of Development Unit is required. Replace Development Unit(s).	It is time to replace the color or the black development Unit(s).	Replace the color or the black Development Unit(s). See "Replacing Consumables and Maintenance Kit" in Maintenance Guide 1.
Replacement of Photoconductor Unit is required. Replace Photoconductor Unit.	It is time to replace the color or the black Photoconductor Unit.	Replace the color or the black Photoconductor Unit. Depending on your service contract, contact your sales or service representative. See "Replacing Consumables and Maintenance Kit" in Maintenance Guide 1.
Reset duplex unit correctly.	The duplex paper feed unit is not set correctly or is not set.	Remove and re-install the duplex paper feed unit correctly. See "Setting Up" in the Setup Guide.
Reset tray # correctly, or select another tray and press <b>[Continue]</b> . To cancel job, press <b>[Reset]</b> . Required:<xxx> <yyy>	The indicated paper input tray is not set correctly, or is not set. #: tray number <xxx>: paper size <yyy>: paper type	Set the indicated paper input tray correctly.
RPCS graphic error.	The graphic is not initialized because the graphic memory was not reserved.	Replace the installed memory.



Messages	Description	Solution
RPCS memory overflow.	The printer memory is not initialized because the CDC memory was not reserved via the system call.	Replace the installed memory.
RPCS syntax error.	The printer identified a syntax error. This error results from; data transmogrification caused by the transmission path problem, data interruption, data transmission from other drivers, etc.	Be sure to use the correct driver.
SDRAM module could not be recognized. Call service.	The printer identified an optional SDRAM error.	Remove and re-install the optional SDRAM. If the message appears again, contact your sales or service representative.
Selected paper tray is in use for another function. Please wait.	The input paper tray selected by the printer driver is being used for another function.	Wait until the job will be completed.
Shift tray has a problem. Call service representative.	Malfunction occurs when using the Shift function	Contact your sales or service representative.
Staple has been cancelled.	The staple feature has been cancelled.	Verify that the paper orientation and layout is properly set, and make sure whether your desired settings or finisher is selected.
Staple is almost empty.	Staple is almost empty in the stapler.	Replace staples.
Staple unit has a problem. Call service representative.	There is a problem with the staple unit.	Contact your sales or service representative.





Messages	Description	Solution
Staple unit is in use for another function. Please wait.	Staple unit is in use for another function.	Wait until the staple job will be completed.
Toner Cartridge Setting Error Toner Cartridges are not set properly: Black, Yellow, Magenta, Cyan Open the part as shown and replace the cartridge(s).	The indicated toner cartridge(s) is/are not set correctly, or is not set.	Set the indicated toner cartridge(s) correctly. See "Replacing Consumables and Maintenance Kit" in Maintenance Guide 1.
Toner is almost empty. Replace Toner Bottle.	The printer is almost out of indicated toner.	Replace the indicated toner cartridge(s).
Transfer Unit Setting Error Transfer Unit is not set properly. Open the part as shown and set the unit.	The transfer unit is not set correctly, or is not set.	Set the Transfer Unit correctly. See "Setting Up" in the Setup Guide.
Tray # has a problem. Select another tray and press <b>[Continue]</b> . To cancel job, press <b>[Reset]</b> . Required:<xxx> <yyy>	There is a problem with the input paper tray #. #: tray number <xxx>: paper size <yyy>: paper type	Turn the main power switch off and then on. If the message appears again, contact your sales or service representative.  <b>Reference</b> Before turning the main power switch, see "Turning Off the Main Power" in Administrator Reference 1.



<b>Messages</b>	<b>Description</b>	<b>Solution</b>
Used toner bottle is full.	The used toner bottle is full of toner dust.	Replace a used toner bottle. See "Replacing Consumables and Maintenance Kit" in Maintenance Guide 1.
Used Toner Bottle Setting Error Used Toner Bottle is not set properly. Open the part as shown and set the bottle.	The used toner bottle is not set correctly, or is not set.	Set the used toner bottle correctly. See "Replacing Consumables and Maintenance Kit" in Maintenance Guide 1.





## Printer Does Not Print

Possible Cause	Solutions
Is the power on?	Confirm that the cable is securely plugged into the power outlet and the printer. Turn on the power switch.
Does the <b>Online</b> indicator stay on?	Press <b>[On Line]</b> so the indicator lights.
Does the <b>Error</b> indicator stay red?	Check the error message on the panel display and take the required action.
Is paper loaded?	Load paper into the paper tray or on the Bypass Tray. See p.12 “Paper and Other Media Supported by This Machine”.
Can you print a configuration page?	If you cannot print a configuration page, it probably indicates a printer malfunction. You should contact your sales or service representative. See “ <i>Printing a Configuration Page</i> ” in Administrator Reference 2.
Is the interface cable connecting the printer to the computer connected securely?	Connect the interface cable properly. If there are any connectors or screws, confirm that they are fastened securely.
Are you using the correct interface cable?	The type of interface cable you should use depends on the computer. Be sure to use the correct one. If the cable is damaged or worn, replace it with a new one. See “ <i>Appendix</i> ” in Administrator Reference 2.



Possible Cause	Solutions
Is the <b>Data In</b> indicator blinking or lit after starting the print job?	<p>If not blinking or lit, the data is not being sent to the printer.</p> <p>❖ <b>If the printer is connected to the computer using the interface cable</b></p> <p>Make sure the printer port settings are correct. For a parallel port connection, port LPT1 or LPT2 should be set.</p> <ul style="list-style-type: none"><li>• <b>Windows 95/98/Me</b><ol style="list-style-type: none"><li>① Click <b>[Start]</b>, point to <b>[Settings]</b>, and then click <b>[Printers]</b>.</li><li>② Click to select the icon of the printer. Next, on the <b>[File]</b> menu, click <b>[Properties]</b>.</li><li>③ Click the <b>[Details]</b> tab.</li><li>④ Check the <b>[Print to the following port]</b> box to confirm that the correct port is selected.</li></ol></li><li>• <b>Windows 2000</b><ol style="list-style-type: none"><li>① Click <b>[Start]</b>, point to <b>[Settings]</b>, and then click <b>[Printers]</b>.</li><li>② Click to select the icon of the printer. Next, on the <b>[File]</b> menu, click <b>[Properties]</b>.</li><li>③ Click the <b>[Port]</b> tab.</li><li>④ Check the <b>[Print to the following port]</b> box to confirm that the correct port is selected.</li></ol></li><li>• <b>Windows NT 4.0</b><ol style="list-style-type: none"><li>① Click <b>[Start]</b>, point to <b>[Settings]</b>, and then click <b>[Printers]</b>.</li><li>② Click to select the icon of the printer. Next, on the <b>[File]</b> menu, click <b>[Properties]</b>.</li><li>③ Click the <b>[Port]</b> tab.</li><li>④ Check the <b>[Print to the following port]</b> box to confirm that the correct port is selected.</li></ol></li></ul>



Possible Cause	Solutions
Is the <b>Data In</b> indicator blinking or lit after starting the print job?	<b>❖ Network Connection</b> Contact your network administrator.
When you use IEEE 1394 Interface Unit Type1045	<ol style="list-style-type: none"><li>① Confirm that the IEEE 1394 Interface Unit Type1045 is attached to the computer correctly.</li><li>② Confirm that the IEEE 1394 interface cable is connected securely.</li><li>③ Unplug the IEEE 1394 interface cable which is connected to the printer.</li><li>④ Restart the computer. If the error occurs even after executing above operation, proceed to the following steps.</li><li>⑤ Execute the utility tool for IEEE 1394 Interface Unit Type1045 which is stored in the following path in the CD-ROM labeled "Printer Drivers and Utilities". <b>UTILITY\1394</b></li></ol> <p><b>❗ Important</b></p> <ul style="list-style-type: none"><li><input type="checkbox"/> For details about using the utility tool for IEEE 1394, see the README file in the same directory in the CD-ROM.</li></ul>



## Other Printing Problems

Status	Possible Causes, Descriptions, and Solutions
Black gradation is not natural.	<ul style="list-style-type: none"><li>• PCL 5c/PostScript Select "CMY+K" for Gray Reproduction in the printer driver's <b>[Advanced...]</b> dialog box under the <b>[Print Quality]</b> tab.</li><li>• RPCS Select "CMY+K" for Gray Reproduction under the <b>[Image Adjustments]</b> tab in the printer driver's <b>[Change User Settings]</b> dialog box.</li></ul>
Color documents are printed in black and white.	<p>The printer driver is not set up for color printing.</p> <ul style="list-style-type: none"><li>• PCL 5c/PostScript Select "Color" for the Color/Black and White under the printer driver's <b>[Setup]</b> tab.</li><li>• RPCS Select "Color" for the Color/Black and White under the printer driver's <b>[Print Settings]</b> tab.</li></ul> <p>For more information, see the printer driver's Help file.</p> <p>Some applications normally print color text as black and white.</p>
Fine dot pattern does not print.	<ul style="list-style-type: none"><li>• PCL 5c/PostScript Change the <b>[Dithering]</b> setting in the Advanced dialog box under the printer driver's the <b>[Print Quality]</b> tab.</li><li>• RPCS Change <b>[Dithering]</b> setting under the <b>[Image Adjustments]</b> tab in the <b>[Change User Settings]</b> dialog box under the <b>[Print Quality]</b> tab in the printer driver's dialog box.</li></ul> <p>For more information, see the printer driver's Help file.</p>



Status	Possible Causes, Descriptions, and Solutions
Images are cut off, or excess pages are printed.	<p>You might be printing on paper smaller than the paper size selected in the application. Use paper the same size as that selected in the application. If you cannot load paper of the correct size, use the reduction function to reduce the image, and then print.</p> <p>See the printer driver's Help file.</p>
It takes too much time to complete the print job.	<p>Photographs and other data intensive pages take a long time for the printer to process, so simply wait when printing such data.</p> <p>Changing the following settings may help to speed up printing.</p> <ul style="list-style-type: none"><li>• <b>PostScript</b> Select "Standard" for Gradation under the <b>[Print Quality]</b> tab in the printer driver's dialog box. Select "Post Script(optimize for speed)" for PostScript output format under the <b>[PostScript]</b> tab in the printer driver's dialog box.</li><li>• <b>RPCS</b> Select "1200×600 dpi" or "600×600 dpi" for Resolution under the <b>[Image Adjustments]</b> tab in the Change User Settings dialog box in the printer dialog box. Select "Speed" for Print priority under <b>[Print Quality]</b> tab in the printer driver's dialog box.</li></ul> <p>For more information, see the printer driver's Help file.</p>
	<p>The data is so large or complex that it takes time to process it. If the <b>Data In</b> indicator is blinking, data processing is being performed. Just wait until it resumes.</p>
	<p>If "Please wait" appears on the panel display, the printer is now warming up. Wait for a while.</p>



Status	Possible Causes, Descriptions, and Solutions
It takes too much time to resume printing.	The data is so large or complex that it takes time to process it. If the <b>Data In</b> indicator is blinking, data processing is being performed. Just wait until it resumes.
	The printer might be set to the Energy Saver mode. In the Energy Saver mode, the printer has to warm up before printing starts. This takes time. To cancel the Energy Saver mode, select "Off" for "Energy Saver 1" in the System Settings menu.
Multiple pages are fed through the printer at once.	Paper misfeeds easily when the Paper Feed Roller is dirty. Contact your sales or service representative to replace the Paper Feed Roller.
Output are not delivered to the selected tray you require.	When using the Bypass Tray, the size selected on the display panel might be different from actual paper size. Select the correct paper size. See <a href="#">p.12 "Paper and Other Media Supported by This Machine"</a> .
	When you are using a Windows operating system, the printer driver settings override those set using the control panel. Set the desired output tray using the printer driver. See the printer driver's Help file.
Paper misfeeds occur frequently.	Check that the side guide of the paper tray is locked. See <a href="#">p.12 "Paper and Other Media Supported by This Machine"</a> . The paper size and feed direction of the paper in the Bypass Tray might not be the same as those you selected with the control panel. Check the settings on the control panel, and load paper of the correct paper size and feed direction. See <a href="#">p.12 "Paper and Other Media Supported by This Machine"</a> .
	Check that the paper guide of the paper tray is attached properly.





Status	Possible Causes, Descriptions, and Solutions
Solid areas, lines or text are shiny or glossy when created as a mixture of cyan, magenta, yellow.	<ul style="list-style-type: none"><li>• PCL 5c/PostScript Select "K(Black)" for Gray Reproduction in the printer driver's <b>[Advanced...]</b> dialog box under the <b>[Print Quality]</b> tab.</li><li>• RPCS Select "K(Black)" for Gray Reproduction under the <b>[Image Adjustments]</b> tab in the printer driver's <b>[Change User Settings]</b> dialog box.</li></ul>
Solid lines are printed as broken lines.	<ul style="list-style-type: none"><li>• PCL 5c/PostScript Change the <b>[Dithering]</b> setting in the Advanced dialog box under the printer driver's <b>[Print Quality]</b> tab.</li><li>• RPCS Change the <b>[Dithering]</b> setting under the <b>[Image Adjustments]</b> tab in the <b>[Change User Settings]</b> dialog box, under the <b>[Print Quality]</b> tab in the printer driver's dialog box.</li></ul> <p>For more information, see the printer driver's Help file.</p>
Some parts of the print image are not clear.	<p>Make the image density darker.</p> <p>To adjust the image density, press the <b>[User Tools/Counter]</b> key, and then press <b>[Printer Features]</b>. Select Image Density from the "Maintenance" menu.</p>
The color of the printout is different from the color on the computer's display.	The toner based color settings with the printer driver causes a drastic change in printout color.
	Changing the color settings with the printer driver causes a drastic change in printout color. See the printer driver's Help file.
The image is printed in the wrong orientation.	The feed direction you selected and the feed direction selected in Option Setup of the printer driver might not be the same. Make the proper settings.
The control panel error message stays on after removing the misfed paper.	Open the front cover of the printer, and then close it.



Status	Possible Causes, Descriptions, and Solutions
The print image is not clear.	Due to a sudden change in temperature, condensation might appear inside the printer, reducing print quality. If this occurs, when you move the printer from a cold room to a warmer room, do not use the printer until it acclimatizes to the temperature.
The print side of the page is a hazy gray.	Adjust the image density. To adjust the image density, press the <b>[User Tools/Counter]</b> key, and then press <b>[Printer Features]</b> . Select Image Density from the "Maintenance" menu. See " <i>Cleaning and Adjusting the Printer</i> " in Maintenance Guide 1.
	If paper is curled, correct it. Curled or folded paper might cause a hazy gray print. Curling often occurs on postcards, so be sure to correct it before printing.
The printed image is different from the image on the computer.	When you use some functions, such as enlargement and reduction, the layout of the image might be different from that displayed in the computer display.
	You might have selected to replace True Type fonts with printer fonts in the printing process. To print an image similar to the image on the computer, make the settings to print out True Type fonts as an image. See the printer driver's Help file.
The printer does not print at 1200dpi, even if 1200dpi resolution is selected.	Printing at 1200dpi uses much memory. Therefore, depending on the memory capacity, you may not be able to print at 1200dpi. Either add memory to the printer, or reduce the size of data to be printed. See " <i>Memory Capacity and Paper Size</i> " in Administrator Reference 2.



Status	Possible Causes, Descriptions, and Solutions
There are color differences in the color documents.	Press the <b>【User Tools/Counter】</b> key, and then select "Color Registration" from the "Maintenance" menu. See " <i>Cleaning and Adjusting the Printer</i> " in Maintenance Guide 1.

 **Note**

- If the problem cannot be solved, contact your sales or service representative.



## Removing Misfed Paper

If a paper misfeed occurs, an error message appears indicating the location of the misfed paper on the panel display. This printer has the auto-recovery function, by which misfed paper is sent to the standard tray or right cover. Usually, you can remove the misfed paper easily with this function.

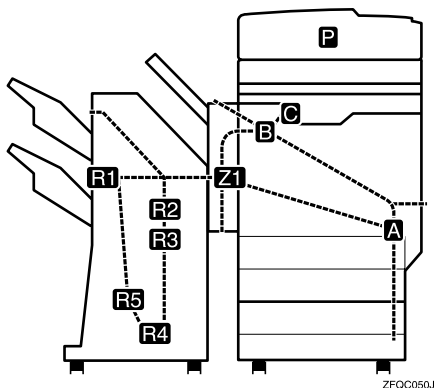

### Note

- More than one misfed area may be indicated. In this case, check every applicable area.
- You can find a sticker explaining how to remove misfed paper inside the front cover or inside the finisher.

### Important

- When clearing misfeeds, do not turn off the operation switch. If you do, your machine settings are cleared.
- To prevent misfeeds, do not leave any torn scraps of paper within the machine.
- If paper misfeeds occur repeatedly, contact your service representative.



## Detaching the 2 Tray Finisher

There are times when you might have to detach the 2 Tray Finisher from the printer to remove misfed paper. This section describes how to detach the 2 Tray Finisher.

- 1** Hold the handle at the top of the 2 Tray Finisher firmly with one hand, pull the 2 Tray Finisher straight out until it stops.

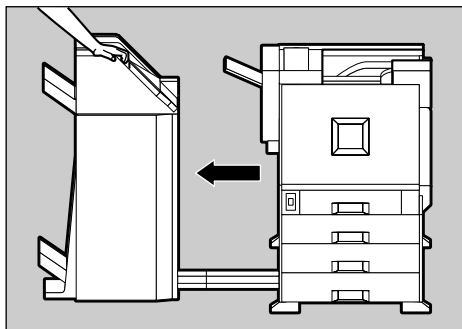

The 2 Tray Finisher is detached from the printer.

- 2** Use both hands to push it straight back in until it clicks into place.

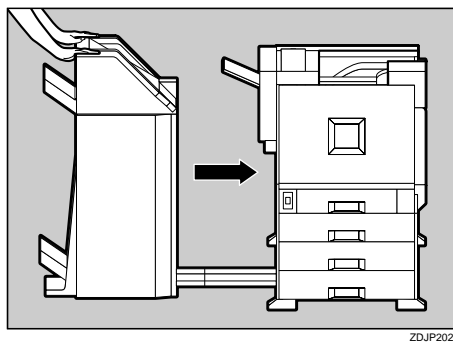

The 2 Tray Finisher is reattached to the printer.

### Important

- Attach the 2 Tray Finisher to the printer after closing the Duplex Reversal Unit.



## Detaching the PT460 (Multi-bin)

When replacing various units or removing misfed paper, the Duplex Reversal Unit is opened. If the optional PT460 (Multi-bin) is attached to the Duplex Reversal Unit, detach it before opening the Duplex Reversal Unit. After closing the Duplex Reversal Unit, reattach the optional PT460 (Multi-bin).

- 1** Raise the External Tray attached to the Duplex Reversal Unit.

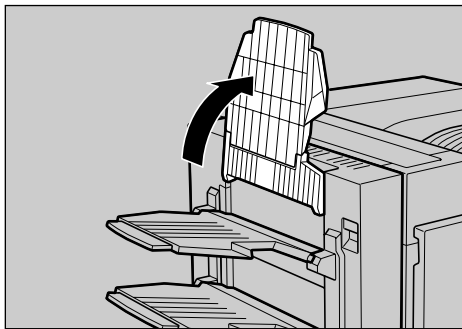

ZFQP010J

- 2** Pull the upper tray of the PT460 (Multi-bin) out and up creating a slant.

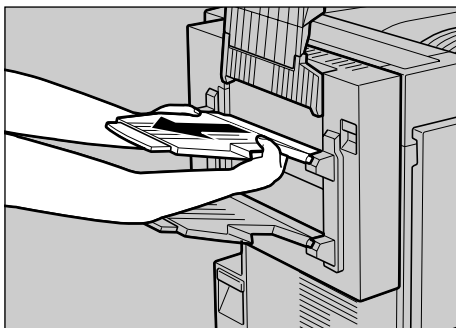

ZFQP020J

- 3** Pull the lower tray of the PT460 (Multi-bin) out and up to detach it as in step 2.

This completes the detachment of the PT460 (Multi-bin).



- 4** Raise the External Tray attached to the Duplex Reversal Unit

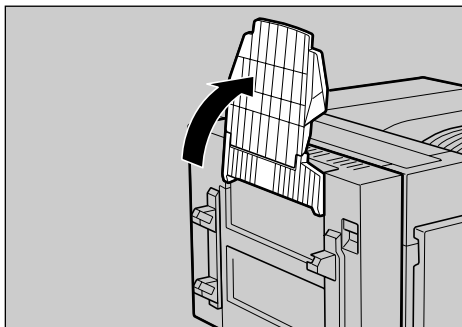

ZFQP011J

- 5** Insert the hooks on both sides of the lower tray of the PT460 (Multi-bin) into the slots.

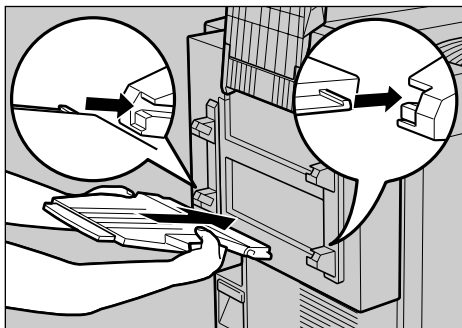

ZFQP040J

- 6** Insert the hooks on both sides of the upper tray of the PT460 (Multi-bin) into the slots as in step 5.

This completes the reattachment of the PT460 (Multi-bin) to the Duplex Unit.

---

## Opening and Closing the Duplex Reversal Unit

---

There are times when you might have to detach the Duplex Reversal Unit to remove misfed paper. This section describes how to detach the Duplex Reversal Unit.

- 1** Push up the lock release button and keep it in place.

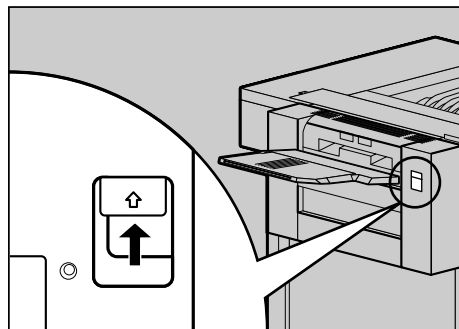

ZDJP203J



- 2** Lower the Duplex Reversal Unit slowly until it stops.

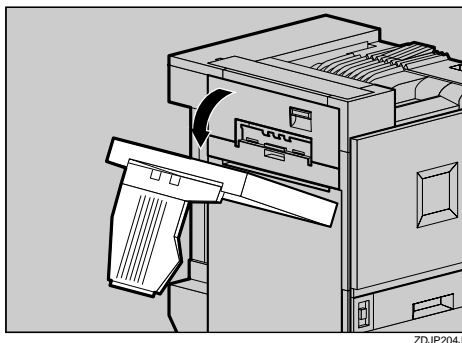

ZDJP204J

**Important**

- Open the Duplex Reversal Unit after detaching the 2 Tray Finisher from the printer.

**Note**

- You do not have to remove the output tray even if the 2 Tray Finisher is attached.

The Duplex Reversal Unit is opened.

- 3** Raise the Duplex Reversal Unit slowly with both hands, and push it in until it clicks into place.

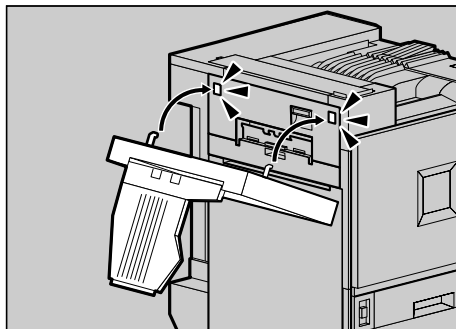

ZDJP205J

The Duplex Reversal Unit is closed.

**Important**

- Attach the Duplex Reversal Unit after closing the upper left cover for the printer.





## When "Paper Misfeed: A" Appears

**1** Open the right cover.

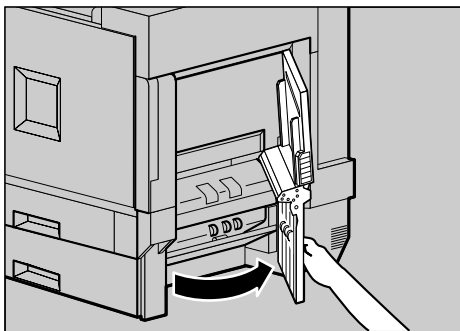

**2** Move the blue lever up and down to feed the misfed paper, and then pull out the paper slowly.

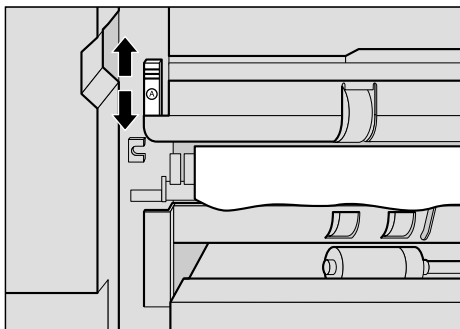

**3** Close the right cover by pushing the area labeled "PUSH".

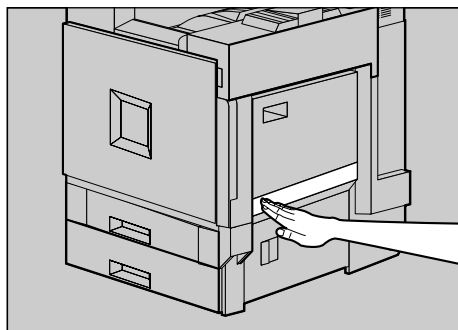



## When "Paper Misfeed: B" Appears

### CAUTION:

- The inside of the machine becomes very hot. Do not touch the parts with a label indicating a "hot surface". Touching a "hot surface" could result in a burn.

**1** If the 2 Tray Finisher is installed, detach it from the printer.

#### Reference

⇒ p.69 "Detaching the 2 Tray Finisher"

**2** If the Duplex Unit is installed, open the Duplex Reversal Unit.

#### Reference

⇒ p.71 "Opening and Closing the Duplex Reversal Unit"

**3** If the output tray is attached to the printer, raise it in the direction of the arrow (①), and remove it (②).

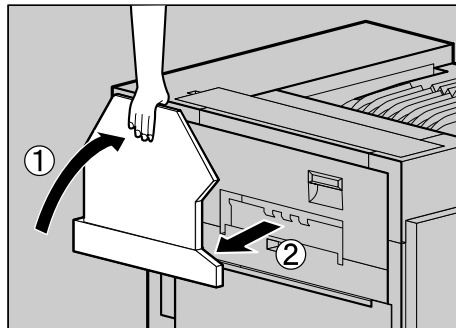

ZDJP038J

**4** Pull out the upper left cover for the printer slowly.

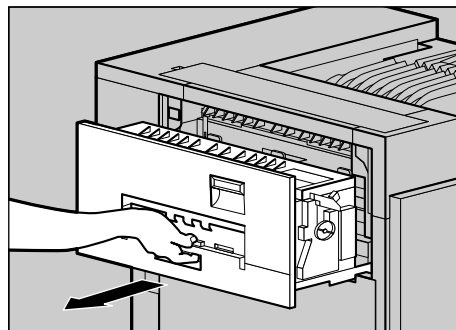

ZDJH047J

- 5** Open the upper left cover.

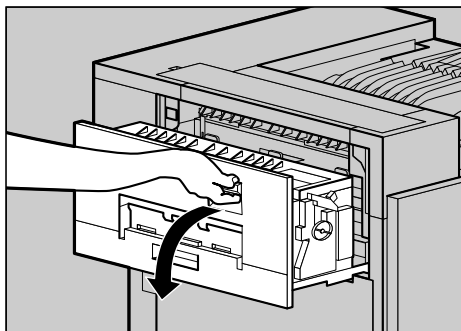

- 6** Turn the blue dial in the direction of the arrow to feed the misfed paper, and pull out the paper slowly.

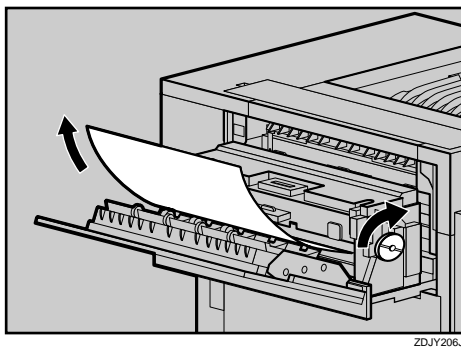

**Important**

- Always turn the blue dial in the direction of the arrow. If you turn it in the reverse direction, the paper feeds into the printer, making it difficult for you to take out the paper.
- Do not pull out the misfed paper. Use the blue dial to feed misfed paper.

- 7** Close the upper left cover (①) and push the handle slowly to the back until it clicks into place (②).

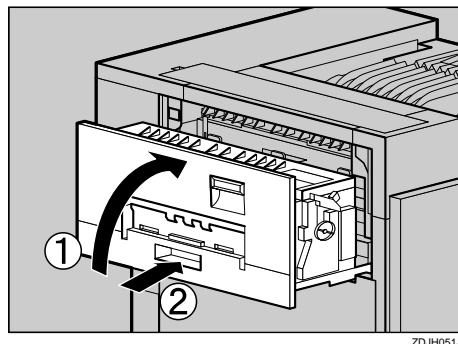



- 8** If you removed the output tray in step **3**, reattach it to the printer. Insert the hooks of the output tray into the printer slits, and lower it toward you.

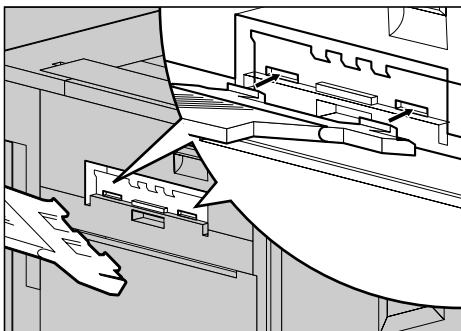

ZDJH010J

- 9** If the Duplex Unit is installed, close the Duplex Reversal Unit.

**Reference**

⇒ p.71 "Opening and Closing the Duplex Reversal Unit"

- 10** If the 2 Tray Finisher was installed, reattach the 2 Tray Finisher to the printer.

**Reference**

⇒ p.69 "Detaching the 2 Tray Finisher"

## When "Paper Misfeed: R" Appears

Open the top cover (①) and front cover (②) of the 2 Tray Finisher, and remove the misfed paper.

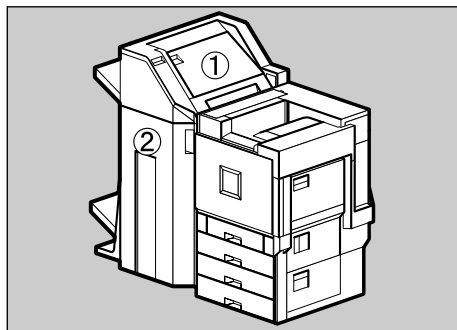

ZDJP206J

- 1** Fold the output tray.



**1** Raise it vertically.

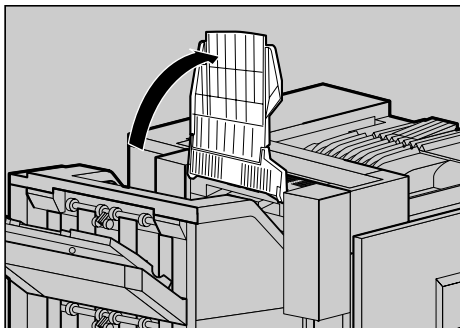

ZDJP207J

**2** Fold it along the printer body.

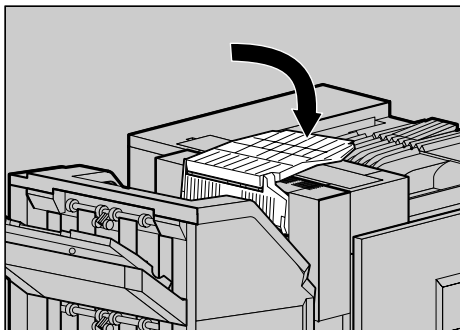

ZDJP208J

**2** Open the top cover for the 2 Tray Finisher, and pull out the misfed paper slowly.

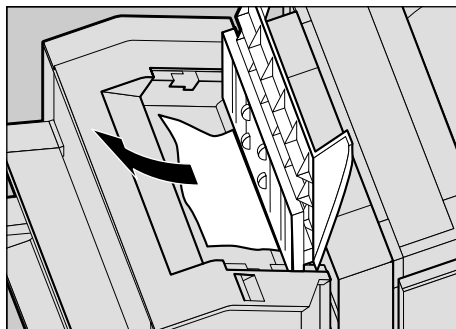

ZDJY208J

**3** Close the top cover slowly.





- 4** Open the front cover for the 2 Tray Finisher.

Check to see if there is misfed paper in areas A, B, C, and D.

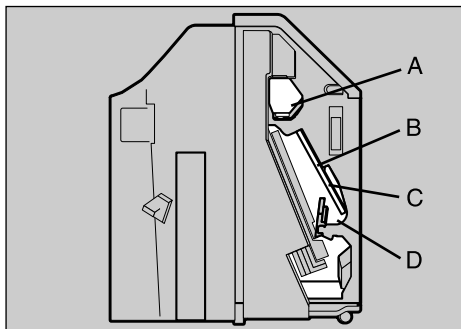

ZD-JP209J

- 5** Check area A of step 4. Lift the lever (①), and while supporting it with your hand to keep it from lowering, pull out the misfed paper slowly.

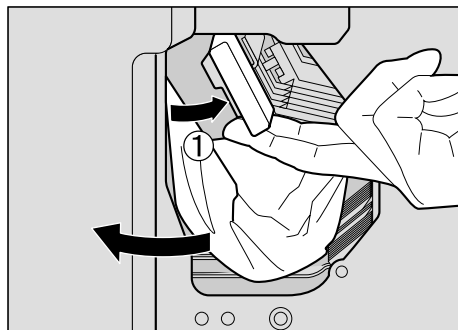

ZD-JP210J

- 6** Lower the lever slowly to return it into place.



- 7** Check areas B and C of step **4**. Lower the lever in the direction of the arrows (①), and pull out the misfed paper slowly.

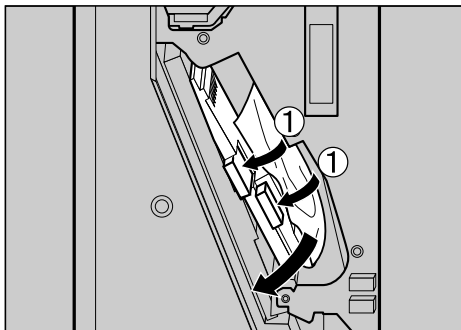

- 8** Lift the lever slowly to return it into place.

- 9** Check area D of step **4**. Lift the lever in the direction of the arrow (①), and pull out the misfed paper slowly.

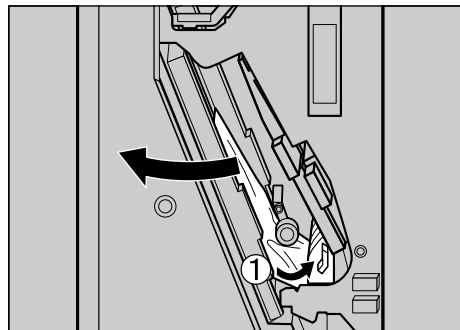

- 10** Lower the lever slowly to return it into place.

- 11** Close the front cover for the 2 Tray Finisher.

If the error message does not clear even after the misfed paper is removed, detach the 2 Tray Finisher from the printer to check for misfed paper there.

 **Reference**

See [p.69](#) “Detaching the 2 Tray Finisher” for details about how to detach/reattach the 2 Tray Finisher from/to the printer.



**12** Return the output tray back into place.

**1** Raise the tray.

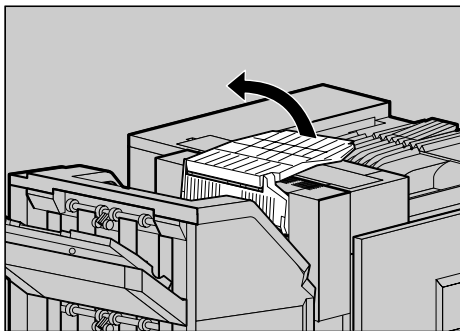

ZDJP085J

**2** Lower it slowly.

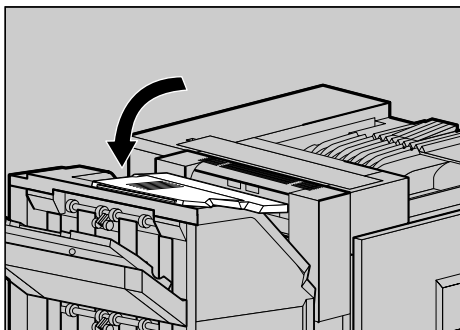

ZDJP086J

---

**When "Paper Misfeed:Y" Appears**

---

**1** Open the lower right cover for the Paper Feed Unit, and pull out the misfed paper.

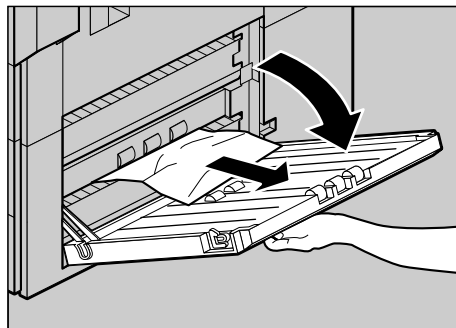

ZDJY208J

**2** Close the lower right cover for the Paper Feed Unit.





## When "Paper Misfeed: Z1" Appears

### CAUTION:

- *The inside of the machine becomes very hot. Do not touch the parts with a label indicating a "hot surface". Touching a "hot surface" could result in a burn.*

**1** If the 2 Tray Finisher is installed, detach it from the printer.



### Reference

⇒ p.69 "Detaching the 2 Tray Finisher"

**2** Open the left cover for the Duplex Reversal Unit, and remove the misfed paper. Do not pull the paper out by force.

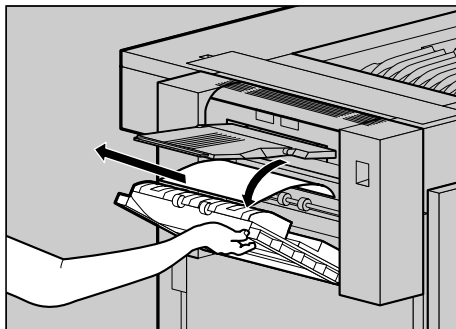

ZD.JY210J

If you cannot remove the paper, proceed to step **3**.



- 3** Push up the lock release button for the Duplex Reversal Unit, and then hold it in place.

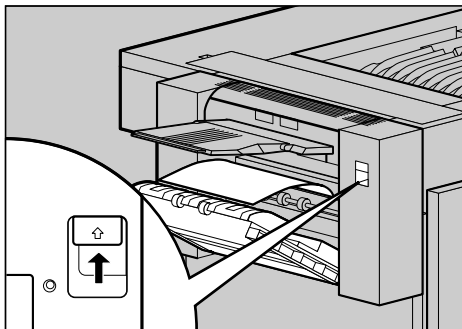

- 5** Raise the Duplex Reversal Unit slowly and insert until it clicks into place. Raise the left cover, and close it securely by pushing the area labeled "PUSH".

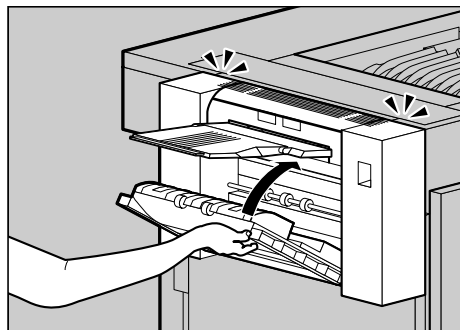

- 4** Lower the Duplex Reversal Unit slowly until it stops, and remove the misfed paper.

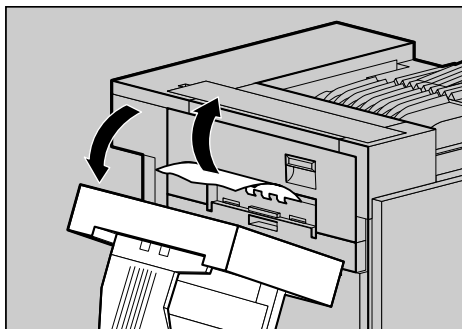



---

## When "Original Misfeed: P" Appears

---

- 1** Pull up the lever (①) and then open the upper cover (②).

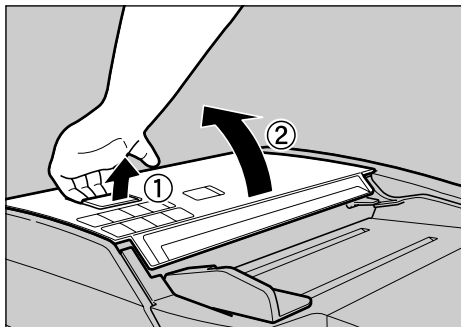

ZFOY010J

- 2** Lift the part in the illustration while squeezing its blue part.

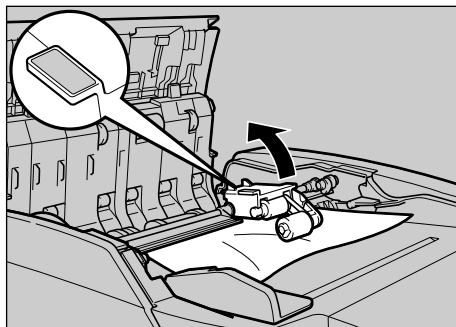

ZFOY020J

- 3** Hold the part in the illustration and slowly remove the misfed paper.

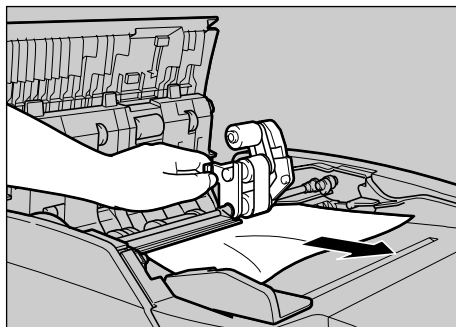

ZFOY030J



- 4** Lower the part in the illustration back into place.

If you cannot remove the misfed paper, go to step **5**.

- 5** Turn the dial in the direction of the arrow, feed the misfed paper, and then slowly remove the paper.

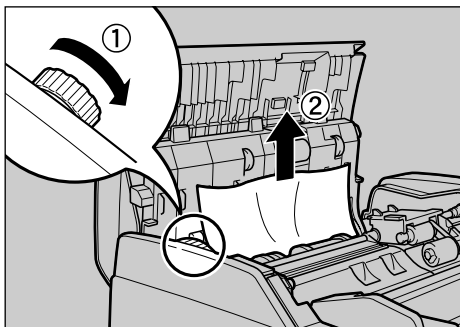

ZFY040J

If you cannot remove the paper, go to step **6**.

- 6** Hold the blue parts of the panel, and then move the panel in the direction of the arrow in the illustration.

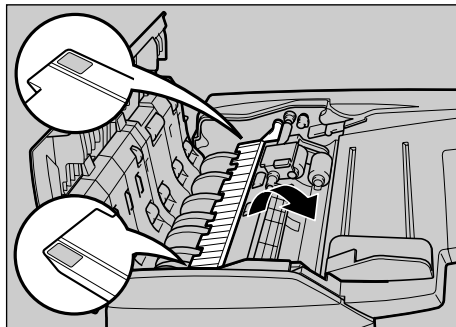

ZFY050J

- 7** Slowly remove the misfed paper.

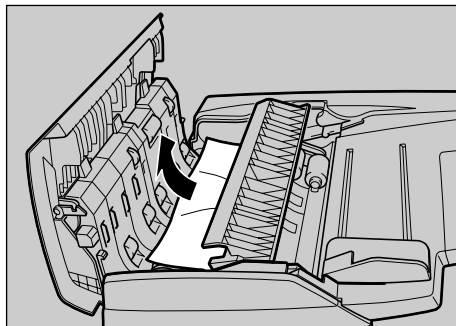

ZFY060J

- 8** Hold the blue parts of the panel and move the panel back into place.

If you cannot remove the misfed paper, go to step **9**.

- 9** Hold the ADF external cover (①), and then slowly remove the misfed paper (②).

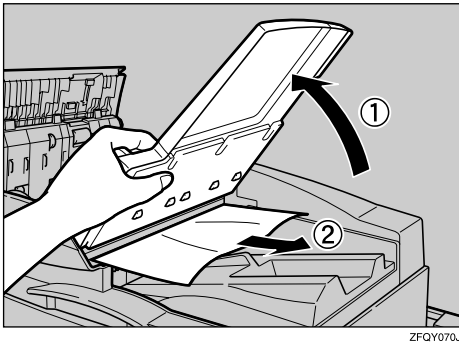

- 10** Lower the ADF external cover back into place.

- 11** Close the upper cover.

If you cannot remove the misfed paper, go to step **12**.

- 12** Open the Auto Document Feeder.

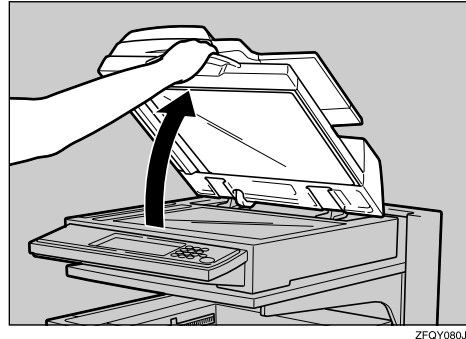

- 13** Move the blue hook to the left and loosen the white cover.

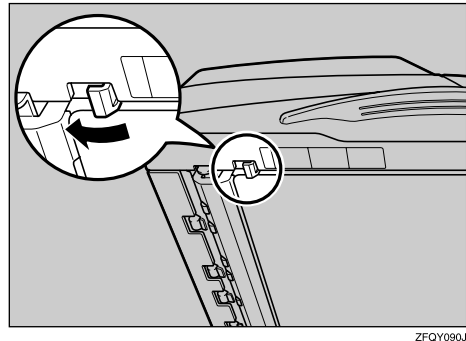



- 14** Pull the white cover toward you and slowly remove the misfed paper.

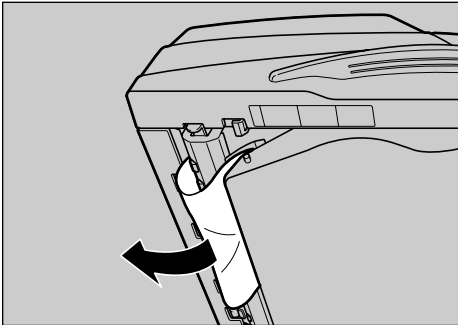

ZFOY100J

- 15** Hold the middle part on the left of the white cover until it clicks into place.

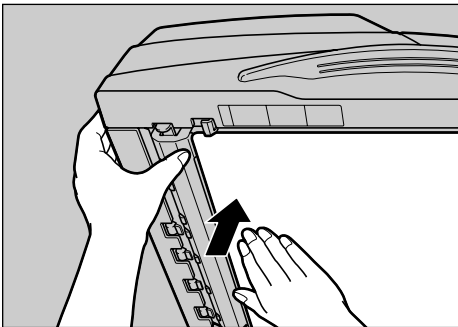

ZFOY110J

- 16** Close the Auto Document Feeder.



## Removing Jammed Staples

When "Add Staples " appears on the panel display, or when the printer does not staple even after it is instructed to, the staples might be jammed.

- 1** Open the front cover of the 2 Tray Finisher.

The stapler is attached to the position shown in the illustration.

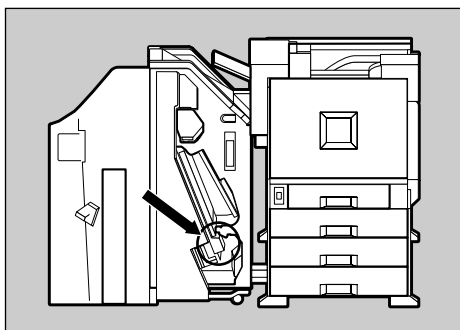

- 2** Remove the cartridge by pulling the green knob in the direction of the arrow.

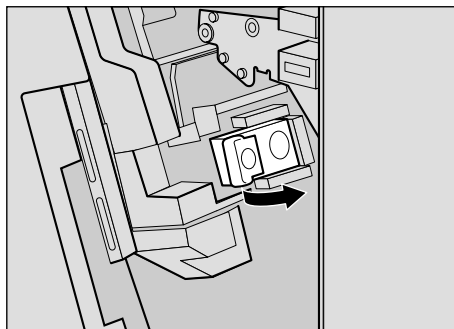



- 3** Open the face plate of the cartridge to unlock it.

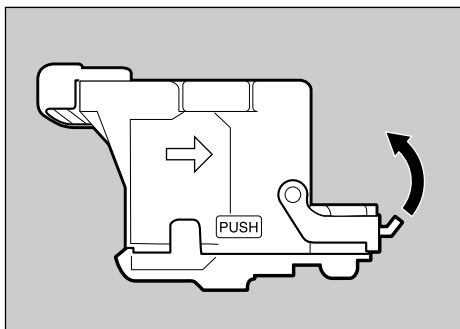

ZDJP227J

- 5** Close the face plate of the cartridge until it clicks into place.

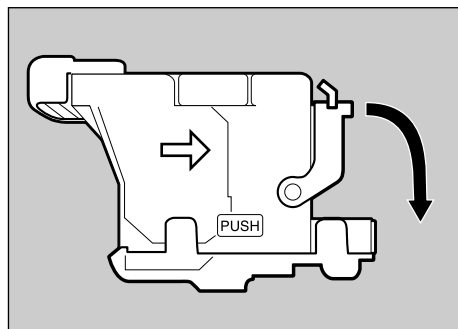

ZDJP229J

- 4** Remove the jammed staples.

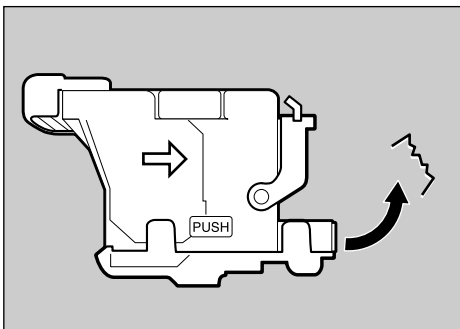

ZDJP228J

- 6** Slant and insert the cartridge (1), and push in until it clicks into place (2).

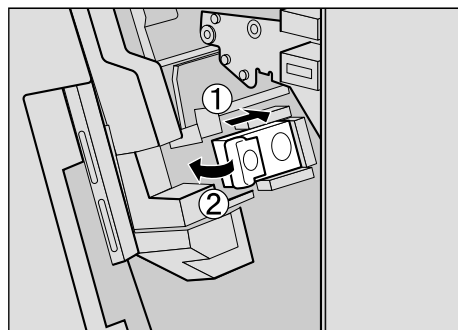

ZDJP218J

- 7** Close the front cover of the 2 Tray Finisher.





## Adding Staples

When "Add Staples " appears on the panel display, add a new staple refill.

- 1** Open the front cover of the 2 Tray Finisher.

The stapler is attached to the position shown in the illustration.

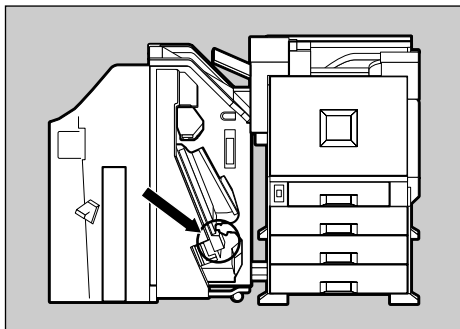

ZDJP216J

- 2** Remove the cartridge by pulling the green knob in the direction of the arrow.

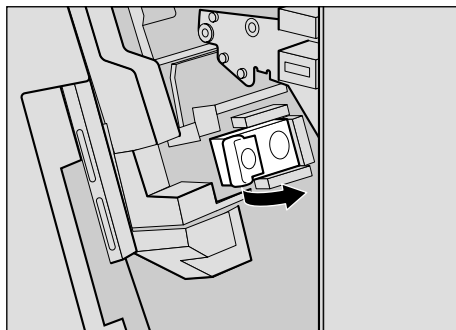

ZDJP217J



- 3** Push the areas labeled "PUSH" located on both sides of the stapler.

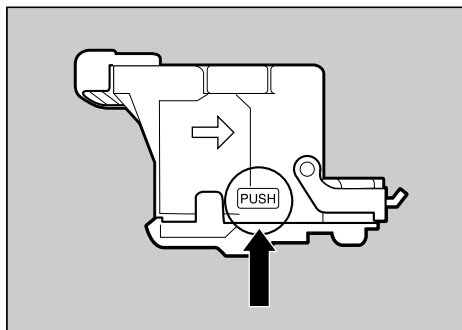

ZDJP222J

The case cover at top floats up.

- 4** Pull the case cover up.

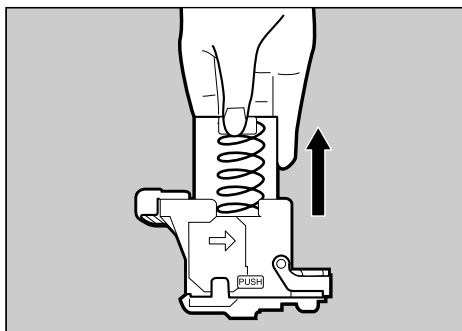

ZDJP223J

- 5** Hook your finger in the hole of the empty refill case to pull it out.

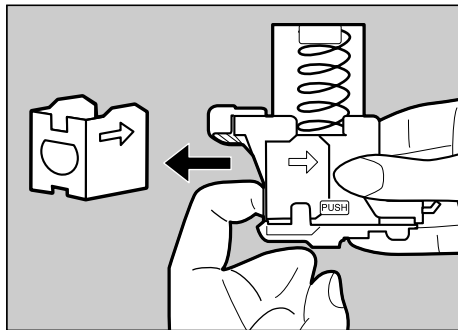

ZDJP224J

- 6** Insert the new refill case in the direction of the arrow until it clicks into place.

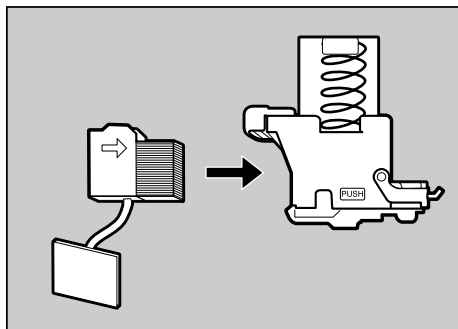

ZDJP225J



- 7** Push the case cover down until it clicks into place.

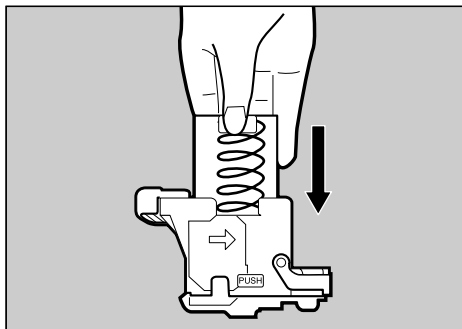

ZDJP230J

- 9** Slant and insert the cartridge (①), and push in until it clicks into place (②).

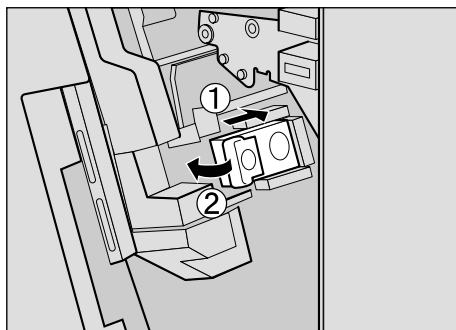

ZDJP218J

- 8** Pull out the ribbon used for bundling the staples.

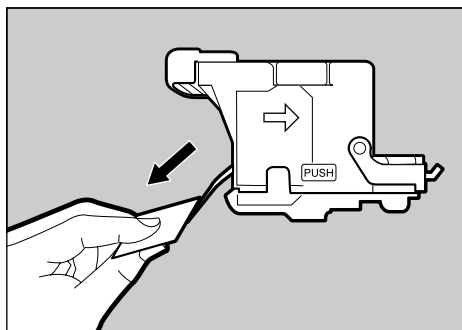

ZDJP226J

- 10** Close the front cover of the 2 Tray Finisher.

 **Note**

- Remove the entire length of the ribbon.



## Removing Punch-hole Chips

When "Hole punch receptacle is full. Empty it." appears on the panel display, the punch waste box is full. Follow these steps to remove paper chips.

### Note

- The same message appears when the punch waste box is not installed correctly.

### **1** Open the front cover of the 2 Tray Finisher.

The punch waste box is attached to the position shown in the illustration.

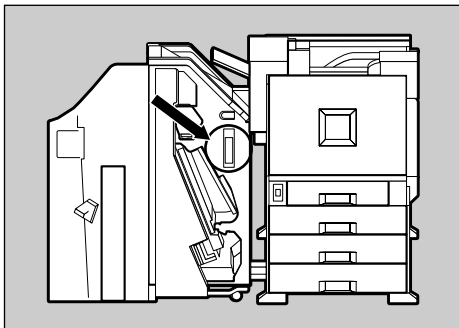

### **2** Pull out the punch waste box and remove the paper chips.



### **3** Reinstall the punch waste box.

### **4** Close the front cover of the 2 Tray Finisher.



---

## When the message appears even after removing the Punch-hole chips

---

If the "Hole punch receptacle is full. Empty it." message appears on the control panel even when the punch waste box is not full, Punch-hole Chips might be stuck around the punch waste box hole as shown in the illustration. Remove the Punch-hole chips around the hole.

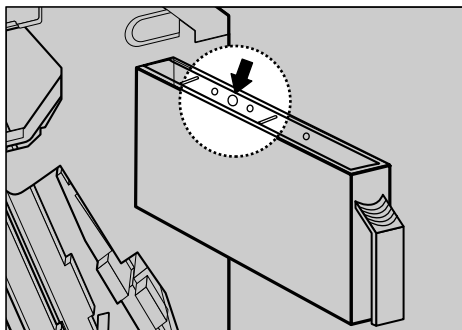

ZBGH030N



# INDEX

## A

---

Adding Staples, 89

## B

---

Bypass Tray

*Custom Size*, 41

*Paper Type*, 43

## D

---

Data In indicator, 60, 61

Detaching the 2 Tray Finisher, 69

Display panel, messages, 45

## E

---

Envelopes, 26

Error, 45

Error indicator, 59

Exposure glass, 7

## L

---

Loading Paper, 23, 30

*Optional Paper Feed Unit*, 31

*Tray 1*, 30

*Tray 2*, 31

Loading paper

*Bypass Tray*, 38

*Paper Bank PS470*, 34

*paper size*, 35

*paper type*, 37

## M

---

messages, 45

## O

---

OHP transparencies, 25

Online key, 59

Opening and Closing the Duplex Reversal Unit, 71

Originals, 6

Other Printing Problems, 62

## P

---

Paper and Other Media, 12

Paper Size, 12

Plain Paper, 24

Printable Area, 29

Printer Does Not Print, 59



## R

---

Remove Misfed Paper

*Duplex Unit*, 81

*Finisher*, 76

*Fusing Unit*, 74

*Internal Path*, 73

*Paper Tray*, 80

Removing Jammed Staples, 87

Removing Misfed Paper, 68

Removing Punch-hole Chips, 92

## S

---

Storing Paper, 23

## T

---

Thick Paper, 24

Troubleshooting, 45

